

User Guide

Kyocera
3245
Kyocera 3200 Series



User Guide for the Kyocera 3245 phone

This manual is based on the production version of the Kyocera 3245 phone. Software changes may have occurred after this printing. Kyocera reserves the right to make changes in technical and product specifications without prior notice. The products and equipment described in this documentation are manufactured under license from QUALCOMM Incorporated under one or more of the following U.S. patents:

4,901,307	5,056,109	5,099,204	5,101,501	5,103,459
5,107,225	5,109,390	5,193,094	5,228,054	5,257,283
5,265,119	5,267,261	5,267,262	5,280,472	5,283,536
5,289,527	5,307,405	5,309,474	5,337,338	5,339,046
5,341,456	5,383,219	5,392,287	5,396,516	D356,560
5,408,697	5,414,728	5,414,796	5,416,797	5,426,392
5,437,055	D361,065	5,442,322	5,442,627	5,452,473
5,461,639	5,469,115	5,469,471	5,471,497	5,475,870
5,479,475	5,483,696	5,485,486	5,487,175	5,490,165
5,497,395	5,499,280	5,504,773	5,506,865	5,509,015
5,509,035	5,511,067	5,511,073	5,513,176	5,515,177
5,517,323	5,519,761	5,528,593	5,530,928	5,533,011
5,535,239	5,539,531	5,544,196	5,544,223	5,546,459
5,548,812	5,559,881	5,559,865	5,561,618	5,564,083
5,566,000	5,566,206	5,566,357	5,568,483	5,574,773
5,574,987	D375,750	5,576,662	5,577,022	5,577,265
D375,937	5,588,043	D376,804	5,589,756	5,590,069
5,590,406	5,590,408	5,592,548	5,594,718	5,596,570
5,600,754	5,602,834	5,602,833	5,603,096	5,604,459
5,604,730	5,608,722	5,614,806	5,617,060	5,621,752
5,621,784	5,621,853	5,625,876	5,627,857	5,629,955
5,629,975	5,638,412	5,640,414	5,642,398	5,644,591
5,644,596	5,646,991	5,652,814	5,654,979	5,655,220
5,657,420	5,659,569	5,663,807	5,666,122	5,673,259
5,675,581	5,675,644	5,680,395	5,687,229	D386,186
5,689,557	5,691,974	5,692,006	5,696,468	5,697,055
5,703,902	5,704,001	5,708,448	5,710,521	5,710,758
5,710,768	5,710,784	5,715,236	5,715,526	5,722,044
5,722,053	5,722,061	5,722,063	5,724,385	5,727,123
5,729,540	5,732,134	5,732,341	5,734,716	5,737,687
5,737,708	5,742,734	D393,856	5,748,104	5,751,725
5,751,761	5,751,901	5,754,533	5,754,542	5,754,733

5,757,767	5,757,858	5,758,266	5,761,204	5,764,687
5,774,496	5,777,990	5,778,024	5,778,338	5,781,543
5,781,856	5,781,867	5,784,406	5,784,532	5,790,589
5,790,632	5,793,338	D397,110	5,799,005	5,799,254
5,802,105	5,805,648	5,805,843	5,812,036	5,812,094
5,812,097	5,812,538	5,812,607	5,812,651	5,812,938
5,818,871	5,822,318	5,825,253	5,828,348	5,828,661
5,835,065	5,835,847	5,839,052	5,841,806	5,842,124
5,844,784	5,844,885	5,844,899	5,844,985	5,848,063
5,848,099	5,850,612	5,852,421	5,854,565	5,854,786
5,857,147	5,859,612	5,859,838	5,859,840	5,861,844
5,862,471	5,862,474	5,864,760	5,864,763	5,867,527
5,867,763	5,870,427	5,870,431	5,870,674	5,872,481
5,872,774	5,872,775	5,872,823	5,877,942	5,878,036
5,870,631	5,881,053	5,881,368	5,884,157	5,884,193
5,884,196	5,892,178	5,892,758	5,892,774	5,892,816
5,892,916	5,893,035	D407,701	5,898,920	5,903,554
5,903,862	D409,561	5,907,167	5,909,434	5,910,752
5,911,128	5,912,882	D410,893	5,914,950	5,915,235
5,917,708	5,917,811	5,917,812	5,917,837	5,920,284
D411,823	5,923,650	5,923,705	5,926,143	5,926,470
5,926,500	5,926,786	5,930,230	5,930,692	

Other patents pending.

Kyocera is a registered trademark of Kyocera Corporation. Brick Attack, Doodler, Race 21, and the arrangement of blue LEDs are trademarks of Kyocera Wireless Corp. QUALCOMM is a registered trademark of QUALCOMM Incorporated. Tetris is a registered trademark of Elorg Company LLC. Openwave is a trademark of Openwave Systems Incorporated. eZiText is a registered trademark of Zi Corporation. All other trademarks are the property of their respective owners.

Copyright © 2003 Kyocera Wireless Corp. All rights reserved.

Ringer Tones Copyright © 2000-2002 Kyocera Wireless Corp.

82-K5348-3EN, Rev. 001

FCC/IC Notice

This device complies with part 15 of the FCC rules. Operation is subject to the following two conditions: (1) This device may not cause harmful interference, and (2) this device must accept any interference received, including interference that may cause undesired operation.

To maintain compliance with FCC RF exposure guidelines, if you wear a headset on your body, use the Kyocera Wireless Corp. (KWC) supplied and approved leather case CA90-61068 and universal belt clip 50-61083-01).

Other accessories used with this device for body-worn operations must not contain any metallic components and must provide at least 22.5 mm separation distance including the antenna and the user's body.

THIS MODEL PHONE MEETS THE GOVERNMENT'S REQUIREMENTS FOR EXPOSURE TO RADIO WAVES.

Your wireless phone is a radio transmitter and receiver. It is designed and manufactured not to exceed the emission limits for exposure to radio frequency (RF) energy set by the Federal Communications Commission of the U.S. Government. These limits are part of comprehensive guidelines and establish permitted levels of RF energy for the general population. The guidelines are based on standards that were developed by independent scientific organizations through periodic and thorough evaluation of scientific studies. The standards include a substantial safety margin designed to assure the safety of all persons, regardless of age and health.

The exposure standard for wireless mobile phones employs a unit of measurement known as the Specific Absorption Rate, or SAR. The SAR limit set by the FCC is 1.6 W/kg.* Tests for SAR are conducted using standard operating positions specified by the FCC with the phone transmitting at its highest certified power level in all tested frequency bands.

Although the SAR is determined at the highest certified power level, the actual SAR level of the phone while operating can be well below the maximum value. This is because the phone is designed to operate at multiple power levels so as to use only the power required to reach the network. In general, the closer you are to a wireless base station antenna, the lower the power output.

Before a phone model is available for sale to the public, it must be tested and certified to the FCC that it does not exceed the limit established by the government-adopted requirement for safe exposure. The tests are performed in positions and locations (e.g., at the ear and worn on the body) as required by the FCC for each model. The highest SAR values for this model phone are:

AMPS mode-head: 1.27 mW/g; Body-worn: 0.441 mW/g with KWC leather case CA90-61068.

PCS mode-head: 1.19 mW/g; Body-worn: 0.222 mW/g with KWC universal belt clip 50-61083-01.

(Body-worn measurements differ among phone models, depending upon availability of accessories and FCC requirements. The body-worn SAR values provided above were obtained by using Kyocera Wireless Corp. (KWC) supplied and approved leather case CA90-61068 and universal belt clip 50-61083-01. The Sports Clip is not designed to be a body-worn accessory).

While there may be differences between the SAR levels of various phones and at various positions, they all meet the government requirement for safe exposure.

The FCC has granted an Equipment Authorization for this model phone with all reported SAR levels evaluated as in compliance with the FCC RF emission guidelines. SAR information on this model phone is on file with the FCC and can be found under the Display Grant section <http://www.fcc.gov/oet/fccid> after searching on FCC ID OVFKWC-3245. Additional information on SAR can be found on the Cellular Telecommunications and Internet Association (CTIA) web-site at <http://www.wow-com.com>.

* In the United States and Canada, the SAR limit for mobile phones used by the public is 1.6 watts/kg (W/kg) averaged over one gram of tissue. The standard incorporates a substantial margin of safety to give additional protection for the public and to account for any variations in measurements.

Caution

The user is cautioned that changes or modifications not expressly approved by the party responsible for compliance could void the warranty and user's authority to operate the equipment.

Warning

Use only Kyocera approved accessories with Kyocera phones. Use of any unauthorized accessories (includes faceplates/front housings) may be dangerous and will invalidate the phone warranty if said accessories cause damage or a defect to the phone.

Optimize your phone's performance

Use the guidelines on page 2 to learn how to optimize the performance and life of your phone, antenna, and battery.

Air bags

If you have an air bag, DO NOT place installed or portable phone equipment or other objects over the air bag or in the air bag deployment area. If equipment is not properly installed, you and your passengers risk serious injury.

Medical devices

Pacemakers—Warning to pacemaker wearers: wireless phones, when in the 'on' position, have been shown to interfere with pacemakers. The phone should be kept at least six (6) inches away from the pacemaker to reduce risk. The Health Industry Manufacturers Association and the wireless technology research community recommend that

you follow these guidelines to minimize the potential for interference.

- Always keep the phone at least six inches (15 centimeters) away from your pacemaker when the phone is turned on.
- Do not carry your phone near your heart.
- Use the ear opposite the pacemaker.
- If you have any reason to suspect that interference is taking place, turn off your phone immediately.

Hearing aids—Some digital wireless phones may interfere with hearing aids. In the event of such interference, you may want to consult your service provider or call the customer service line to discuss alternatives.

Other medical devices—If you use any other personal medical device, consult the manufacturer of the device to determine if it is adequately shielded from external RF energy. Your physician may be able to help you obtain this information.

In health care facilities—Turn your phone off in health care facilities when instructed. Hospitals and health care facilities may be using equipment that is sensitive to external RF energy.

Potentially unsafe areas

Posted facilities—Turn your phone off in any facility when posted notices require you to do so.

Aircraft—FCC regulations prohibit using your phone on a plane that is in the air. Turn your phone off before boarding aircraft.

Vehicles—RF signals may affect improperly installed or inadequately shielded electronic systems in motor vehicles. Check with the manufacturer of the device to determine if it is adequately shielded from external RF energy. Your physician may be able to help you obtain this information.

Blasting areas—Turn off your phone where blasting is in progress. Observe restrictions, and follow any regulations or rules.

Potentially explosive atmospheres—Turn off your phone when you are in any area with a potentially explosive atmosphere. Obey all signs and instructions. Sparks in such areas could cause an explosion or fire, resulting in bodily injury or death.

Areas with a potentially explosive atmosphere are often, but not always, clearly marked. They include:

- fueling areas such as gas stations
- below deck on boats
- transfer or storage facilities for fuel or chemicals
- vehicles using liquefied petroleum gas, such as propane or butane
- areas where the air contains chemicals or particles such as grain, dust, or metal powders
- any other area where you would normally be advised to turn off your vehicle engine

Use with care

Use only in normal position (to ear). Avoid dropping, hitting, bending, or sitting on the phone.

Keep phone dry

If the phone gets wet, turn the power off immediately and contact your dealer. Water damage may not be covered under warranty.

Resetting the phone

If the screen seems frozen and the keypad does not respond to keypresses, reset the phone by completing the following steps:

1. Remove the battery door.
2. Remove and replace the battery.

If the problem persists, return the phone to the dealer for service.

Qualified service

If you are experiencing problems with your phone, see “Getting Help” on page 68. If you have additional questions, contact your service provider for technical support. If the problem persists, return the phone with all accessories and packaging to the dealer for qualified service.

Accessories

Use only Kyocera-approved accessories with Kyocera phones. Use of any unauthorized accessories may be dangerous and will invalidate the phone warranty if said accessories cause damage or a defect to the phone.

To shop online for a Hands-free Car Kit and other phone accessories, visit www.kyocera-wireless.com/store.

To order by phone, call (800) 349-4188 (U.S.A. only) or (858) 882-1410.

Radio frequency (RF) energy

Your telephone is a radio transmitter and receiver. When it is on, it receives and sends out RF energy. Your service provider’s network controls the power of the RF signal. This power level can range from 0.006 to 0.6 watts.

In August 1996, the U.S. Federal Communications Commission (FCC) adopted RF exposure guidelines with safety levels for hand-held wireless phones. These guidelines are consistent with the safety standards previously set by both U.S. and international standards bodies in the following reports:

- ANSI C95.1
(American National Standards Institute, 1992)
- NCRP Report 86 (National Council on Radiation Protection and Measurements, 1986)
- ICNIRP (International Commission on Non-Ionizing Radiation Protection, 1996)

Your phone complies with the standards set by these reports and the FCC guidelines.

E911 Mandates

Where service is available, this handset complies with the Phase I and Phase II E911 Mandates issued by the FCC.

Charger specifications

Charger	Input	Output
CV90-60858-1	100-240VAC / 50/60Hz	4.5V 1.5A
CV90-60859-1	120VAC / 60Hz	5.2V 400mA



093 453 037

Kyocera Wireless Corp.

10300 Campus Point Drive, San Diego, CA 92121 U.S.A.

Visit us at www.kyocera-wireless.com

To purchase accessories, visit
www.kyocera-wireless.com/store

CONTENTS

1	Getting Started	1	Quick reference to text entry	23	
	Installing the battery	1	4	Storing Contacts	24
	Charging the battery	1		Saving a phone number	24
	Getting to know your phone	4		Saving an email address, street address, URL, or note	25
	Using menus	6		Editing or erasing a contact	25
	Using the Sport Clip	9		Editing a phone number	26
2	Making and Answering Calls	10		Finding contact information	27
	Making a call	10		Viewing contacts	28
	Answering a call	10	5	Sending and Receiving Text Messages . .	29
	Setting the phone to hold calls	11		Sending text messages	29
	Using the speakerphone	12		Retrieving text messages	33
	Dealing with missed calls	12		Erasing messages	34
	Setting up speed dialing	14		Customizing message settings	35
	Setting up voicemail	14	6	Customizing Your Phone	38
	Silencing an incoming call	15		Setting vibrate mode	39
	Locking the keypad	15		Silencing all sounds	39
	Receiving data or faxes	16		Choosing a different ringer	40
	Calling emergency numbers	17		Adjusting volume	40
	Understanding roaming	18		Using shortcuts	41
	Muting calls using a headset	19		Personalizing the screen	42
3	Entering Letters, Numbers, and Symbols .	20		Creating a secure environment	45
	Understanding text entry screens	20		Setting message alerts	46
	Text entry modes	20		Switching between phone lines	46
	Capitalization settings	22			

	Data settings	47
	Setting position location	48
7	Using Voice Recognition	49
	Setting up voice dialing	49
	Using voice features with accessories	52
	Training voice recognition	53
8	Connecting to the Internet	54
	Using the Web Browser	54
9	Using Tools	57
	Voice Memo	57
	Scheduler	58
	Alarm Clock	59
	Tip Calculator	60
	Calculator	60
	Timer	61
	Stopwatch	61
10	Fun & Games	62
	Tetris	62
	Brick Attack	63
	Race 21	64
	Doodler	65
	My Sounds	66
	My Pictures	67
11	Getting Help	68
	Index	69

1 GETTING STARTED

This document describes the Kyocera 3245 trimode phone, with CDMA digital service at 800 MHz and 1900 MHz, and analog service at 800 MHz.

Your phone comes with an internal/removable lithium ion (LiIon) battery. **Fully charge the battery before using the phone.**

Installing the battery

1. Hold the phone face down
2. Place the battery in the phone casing with the metal contacts facing the antenna end of the phone.
3. Place the battery door notch in the opening near the bottom of the phone. Push down on the door until it clicks into place.

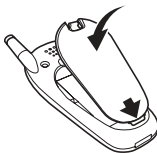



Charging the battery

The battery is partially charged when you receive your phone. You must have at least a partial charge in the battery to make or receive calls, regardless of whether or not the AC adapter is connected to the phone.

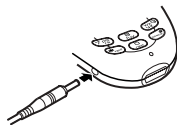
To charge the battery, connect the AC adapter to the jack on the side of the phone (as shown), then connect the adapter's plug to a wall outlet.



The battery icon in the upper-right corner of the screen tells you whether the phone is:

- Charging (the icon is animated)
- Partially charged 
- Fully charged 

Recharging the battery

You can safely recharge the battery at any time, even if it has a partial charge.

Removing the battery

1. Turn off the phone.
2. Hold the phone face down. Press down on the latch on the back of the phone and pull off the battery door.
3. Place your fingernail or the notch in the battery door under the tab on the battery and lift it out of the phone.

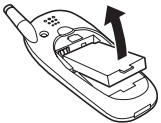

- Never dispose of any battery in or near a fire. It could explode.

Common causes of battery drain

The following functions drain the battery more quickly and adversely affect talk and standby times:

- Playing games or using the Web frequently.
- Frequent use of backlighting.
- Operating in analog mode. If you see an **A** on the home screen, the phone is in analog mode. Your phone switches between modes to find the best signal. To set your phone to operate in a single mode, select **Menu** → **Settings** → **Network** → **Digital/Analog** and choose from the options available.
- Operating in digital mode when far away from a base station or cell site.
- Using data cables or accessories, such as the Hands-free headset.
- Operating when no service is available, or service is available intermittently.
- High earpiece and ringer volume settings.
- Unacknowledged voicemail, page, and text message alerts.













Caring for the battery

This section describes important safety information and tips for improving battery performance.

General safety guidelines

- Do not take apart, puncture, or short-circuit the battery.
- If you have not used the battery for more than a month, recharge it before using your phone.
- Avoid exposing the battery to extreme temperatures, direct sunlight, or high humidity.

Performing basic functions

To...	From the home screen...
Turn the phone on	Press  and wait until the hourglass icon appears.
Turn the phone off	Press and hold  until the message "Powering Off" appears.
Make a call	Enter the number and press  .
End a call	Press  (the red key).
Answer a call	Press  (the green key).
Access voicemail	Press and hold  and follow the system prompts. Contact your service provider for details about their voicemail system.
Verify your phone number	Select Menu → Phone Info .
Silence the ringer	Press  , then  to answer.
Lock the keypad	Press and hold  left.
Access a contacts list	Press  down.
Silence all sounds	Press and hold  right.
Access your shortcuts	Press  up.

Access shortcuts

Lock/ Unlock	◀		▶	Silence all sounds
Access contact list				

Getting to know your phone

- ① **Jack for Hands-free Headset** (sold separately) only.
- ② **Home screen.** Press  (item 6) to select **Menu**.
- ③ **Jack for AC Adapter** (included).
- ④ **Antenna**
- ⑤ **Jack for data cable** (sold separately).

 **Warning:** Inserting an accessory into the incorrect jack will damage the phone.

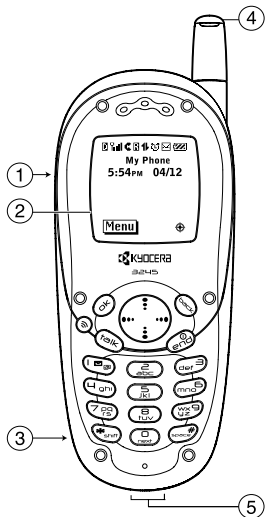

- ⑥ **OK key** selects a menu item or option.
- ⑦ **Speakerphone key** turns the speakerphone on and off.
- ⑧ **Send/Talk key** starts or answers a call.
- ⑨ **Keypad** for entering numbers, letters, or symbols.
- ⑩ *** Shift key** changes the text mode in text entry.
- ⑪ **Back key** erases the last character in text entry, or returns to the previous menu.
- ⑫ **Navigation key** scrolls through lists and positions cursor.
Also accesses shortcuts from the home screen:
(left) locks keypad; (right) silences all sounds;
(up) defines and accesses a personal shortcut;
(down) lists contacts.
- ⑬ **End/Power key** turns the phone on or off, ends a call, or returns you to the home screen.
- ⑭ **Space # key** enters a space during text entry.
- ⑮ **0 Next key** cycles through word choices during eZiText[®] text entry.

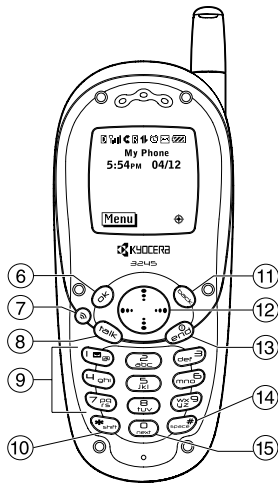

Using menus

The contents of the main menu are as follows:



Recent Calls
Incoming Calls
Outgoing Calls
Missed Calls
Erase Lists



Contacts
View All
Add New
Find Name
Add Voice Dial
Speed Dial List
Voice Dial List
Business List
Personal List
Information



Messages
Voicemail
Send New*
InBox
Net Alerts*
OutBox*
Saved
Erase Msgs
Group Lists*
Msg Settings



Web Browser*
Connects to
Internet



Settings
Silent Mode
Keyguard
Sounds
Display
Voice Services
Security
Call Information
Network
Convenience
Messaging
Accessories



Fun & Games*
Tetris®
Brick Attack™
Race 21™
Doodler™
My Sounds
My Pictures









Tools
Voice Memo
Scheduler
Alarm Clock
Tip Calculator
Calculator
Timer
Stopwatch



Phone Info
Displays the phone
number, ESN, and
software version
your phone is
using.

* Not available on all phones. Check with your service provider.

To use menus

- From the home screen, press  to select **Menu**.
 - Press  left, right, up, or down to see menus.*
 - Press  to select a menu or menu item.
 - Press  up or down to view menu items.
 - Press  to back up a menu level.
 - Press  to return to the home screen.
- * Your menus may appear as graphics or as a list. To change the way they appear, select **Menu** → **Settings** → **Display** → **Main Menu View**, then select either **Graphics** or **List** and press .

Note: In this guide, the use of an arrow → tells you to select an option from a menu. For example, **Menu** → **Settings** means select **Menu**, then select the **Settings** option.

Understanding screen icons

These icons may appear on your phone's screen.

Icons in the top row



The phone is operating in IS2000 (1X) digital mode.



The phone is operating in IS95 digital mode.



The phone is operating in Analog (FM) mode.



The phone is receiving a signal. You can make and receive calls. Fewer bars indicate a weaker signal.



The traffic channel is in use. You can make and receive calls.



The traffic channel is not available. You cannot make or receive calls.



The phone is roaming outside of its home service area.



You have a text message, voicemail, or page. ( indicates an urgent text message, voicemail, or page.)



The battery is fully charged. The more black bars, the greater the charge.



The Scheduler alarm clock is set.



High-speed (3G) data service is available and active on your phone.*

*For availability of high-speed data on your network, check with your service provider.



(blinking) The phone is sending high-speed data.



(blinking) The phone is receiving high-speed data.



High-speed data service is available, but the phone is dormant.



High-speed data is not available on your phone. (Check with your service provider for availability.)

Icons in the bottom row



The phone is at the home screen. To access the menus, press .



Keypad is on. The keypad is locked.



The phone is set to light up instead of ring.



The phone is set to vibrate instead of ring.



The phone is set to show its position location to your service provider as well as emergency services.



The phone is set to show its position location to emergency services only.

eZi

Enter text using eZiText[®] rapid text entry.

aBc

Enter text using normal alpha text entry.



Capitalize the next letter during text entry.



Capitalize every letter during text entry.



Capitalize the first letter of each word (in a contact) or the first letter of each sentence (in a text message) during text entry.

















&?!

Enter symbols.

123

Enter numbers.

Other icons

-  Press  up.
-  Press  down.
-  Press  left.
-  Press  right.
-  Press  to go back or clear an item.
-  Press  to select an item.
-  Outgoing call
-  Incoming call
-  Missed call (flashing)
-  Forwarded call
(Call type may not be available. Check with your service provider.)
-  Three-way call
(Call type may not be available. Check with your service provider.)

Using the Sport Clip

The Sport Clip is a clip built into a battery door. It is designed to attach to a backpack or purse or to stand upright with a fold-out stand. It is not designed to attach to clothing (e.g., a belt).

- To install the Sport Clip, simply remove the standard battery door and clip in the Sport Clip door.





2 MAKING AND ANSWERING CALLS

Making a call



1. Make sure you are in an area where the signal can be received. Look for the  symbol on the home screen.

Note: The more bars you see in this symbol, the clearer the reception will be. If there are no bars, try to move to where the reception is better. In some cases, this can be as simple as changing the direction you're facing. If your phone cannot locate a signal, it changes to power-save mode. If you see the message "Power Save Mode" and a  on the screen, press any key to return to normal operating mode and try your call again.

2. Enter the phone number.
3. Press .
4. Press  to end the call.

Tip: To make calls using your phone's voice recognition feature, see "Calling using voice tags" on page 50.

Redialing a number

To redial the last number called, press  twice. If you see a message prompting you to speak a name, press  again.

Calling a saved number

If you have already saved a phone number, you can use the frequent contacts list to find it quickly.

1. Press  down.

This brings up a list of all saved contacts.

Note: A list of frequent contacts will also appear at the top of the list if you have enabled the frequent contacts setting. For more information, see page 27.



2. Scroll down the list, find the contact you want, and press  to dial the number.

For more about finding contact information, see page 27.

Answering a call

When a call comes in, the phone rings, vibrates, and/or lights up, and a dancing phone icon appears.

The number of the caller also appears if it is not restricted. If the number is stored in your Contacts directory, the contact name appears.

- To answer the call, press .
- If you do not wish to answer the call, select **Silence** or **Ignore** and press . Silence mutes the ringer. Ignore mutes the ringer and returns you to the screen that was active at the time the call came in. Both actions will send the caller to voicemail if you do not pick up the call.
- To place the caller on hold momentarily until you can answer the call, press **Hold**. This will play a recorded message from you telling the caller he/she is on hold.

Note: Before you can place calls on hold, you must first record a message and enable the Hold Call feature. See “Setting the phone to hold calls” on page 11.

Answering calls hands-Free

If your phone is attached to an accessory such as a hands-free car kit or hands-free headset (sold separately), you can use a voice command to answer incoming calls. See “Using voice features with accessories” on page 52.

Setting the phone to hold calls

The Hold Call setting allows you to place incoming calls on hold until you are ready to answer them.

To enable your phone to place calls on hold:

1. Select **Menu** → **Settings** → **Convenience** → **Hold Call**.
2. Select **Enabled**.
3. If you have not recorded a hold message, you will be prompted to record one.
Example: “Please hold. I’ll answer in a minute.”
4. Record the message twice, as prompted.
5. Select **Save**, **Play**, or **Exit**.

The next time a call comes in, you will have the option of placing it on hold.

Placing a call on hold

You can place a call on hold once you have enabled the feature.

Note: If you are already on a call and you receive another call, you cannot place the incoming call on hold. It will go to voicemail.

To place a call on hold:

1. When a call comes in, press  to select **Hold Call**. The caller will be placed on hold and will hear your recorded hold message.
2. To speak to the caller, select **Answer**.

-or-

To hang up without speaking to the caller, select **End Call**.



Changing the hold message

To change your hold message:



1. Select **Menu** → **Settings** → **Convenience** → **Hold Call** → **Re-record Msg.** and follow the prompts.
2. Record the message twice.
3. Select **Save, Play, or Exit**.

Using the speakerphone

You can turn the speakerphone on at any time.



- To turn the speakerphone on, press .
- To answer an incoming call and turn speakerphone on at the same time, press .
- To turn speakerphone off, press .

Adjusting speakerphone volume

1. Select **Menu** → **Settings** → **Sounds** → **Spkrphone Vol.**
2. Press  up and down to adjust volume.
3. Press  to save the new setting.

Dealing with missed calls



When you have missed a call, “Missed” appears on your screen. This message remains, unless the caller leaves a voicemail.

- Press  or  to clear the screen.
- To view the caller’s number or name, select **Calls**. In the Recent Calls list, the missed call is indicated with a flashing .
- If the caller left a voicemail message, select **Call**. If you have not yet set up your voicemail, the caller cannot leave a message. For help setting up voicemail, see page 14.

Setting missed call alerts

You can set an alert to beep every five minutes after you have missed a call.

- Select **Menu** → **Settings** → **Sounds** → **Missed Call** → **Enabled**.

- To turn off the alert when it rings, press  or .
- To cancel the alert, select **Menu** → **Settings** → **Sounds** → **Missed Call** → **Disabled**.

Viewing recent call details

Details on the last 29 calls you made or received are stored in the Recent Calls list. You can get details on the caller's name and phone number, along with the time and length of the call. Icons indicate the types of calls in the list.

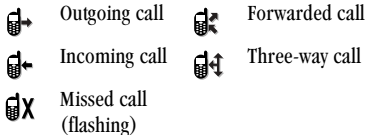



Viewing recent calls

1. Select **Menu** → **Recent Calls**.
2. Select a list: **Incoming Calls**, **Outgoing Calls**, or **Missed Calls**.
3. Select a recent call item.
4. Select an option:

- **Number**—Show the caller's number (for an incoming call), or the number you called (for an outgoing call).
- **Prepend**—Place the cursor at the beginning of the phone number so you can add an area code.
- **Save New**—Save the phone number as a contact.
- **Add to**—Add the phone number to a saved contact.
- **View Contact**—Show details on the contact if the caller's information is already in your Contacts directory.



Note: If the number has been saved as “secret,” you must enter your four-digit lock code to view or edit the number. For information on the lock code, see “Changing your lock code” on page 45. To classify a phone number as secret, see “Saving a phone number” on page 24.

Erasing recent calls

1. **Menu** → **Recent Calls** → **Erase Lists**.
2. Select an option: **Incoming Calls**, **Outgoing Calls**, **Missed Calls**, or **Erase All**.
3. Press  right and press  to select **Yes**.

Setting up speed dialing

Speed dialing allows you to quickly dial a stored phone number by entering a one- or two-digit speed dialing location.

1. Locate a saved contact.
2. Highlight the phone number and press .
3. Select **Speed Dialing**.
4. Select a speed dialing location. (Location “1” is reserved for your voicemail number.)
5. Press  to select **Assign**.

To speed dial



From the home screen, enter the one- or two-digit speed dialing location and press .

Setting up 1-Touch Dialing



1-Touch Dialing is a form of speed dialing that allows you to press and hold a speed dial location to make a call. It is the fastest way to speed dial.

1. Select **Menu** → **Settings** → **Convenience** → **1-Touch Dialing** → **Enabled**.
2. Press .

Using 1-Touch Dialing

To dial a phone number, simply press and hold the assigned speed dialing location for the phone number. If it is a two-digit number, press the first number, then press and hold the second. For example, if the speed dialing number is 15, press , then press and hold .

Removing a speed dialing location

1. Select **Menu** → **Contacts** → **Speed Dial List**.
2. Select a speed dialing location.
3. Highlight the phone number and press .
4. Select **Speed Dialing**.
5. Highlight the number to remove.
6. Press  right to highlight **Remove**.
7. Press .

Setting up voicemail

Before your phone can receive voicemail messages, you must set up a password and record a personal greeting with your service provider. When you have set up your voicemail, all unanswered calls to your phone are automatically transferred to voicemail, even if your phone is in use or turned off.

1. From the home screen, press and hold .

2. Enter your passcode, which you obtain from your service provider.
3. Follow the system prompts to create a password and record a greeting.

Note: If you are having trouble accessing your voicemail, contact your service provider.

Checking voicemail messages

When a voice message is received, your screen will display text similar to: “New Message 1 Voicemail.” This text will remain for about five minutes. After that, look for the  symbol at the top of your screen. The symbol flashes if the message is urgent.

If you see “New Message” on your screen



1. Press  to select **Voice**. This initiates a call to your voicemail number.
2. Follow the prompts to retrieve the message. For specific information on getting voicemail messages, contact your service provider.

If you see the symbol

1. Press  to initiate a call to your voicemail number.
2. Follow the prompts to retrieve the message.

Note: You can set the phone to beep and/or light up every five minutes to remind you that you have voicemail. For more information, see “Setting message alerts” on page 46.

Silencing an incoming call

- To silence an incoming call quickly, press . Then press  to answer the call.





This action silences the current call only. The next call will ring as normal.

Adjusting the volume during a call

- To adjust the earpiece volume during a call, press  up or down.

Locking the keypad

The Keypadguard locks your keypad to prevent accidental keypresses when the phone is turned on and a call is not in progress. You can still answer or silence an incoming call.

- To lock the keypad from the home screen, press  left and hold.
- To unlock the keypad, press    in this order.

Changing the keyguard setting

1. Select **Menu** → **Settings** → **Keyguard**.
2. Highlight an option. You can set the phone to lock the keypad immediately, or automatically if no key is pressed after 30 seconds, 1 minute, or 5 minutes.
3. Press **OK** to save.

Keeping track of your calls

Your phone has two timers that count the amount of calls you have made and received.

All calls

This timer displays the total number and duration of all calls you have made and received. You cannot reset this timer.

- Select **Menu** → **Settings** → **Call Information** → **All Calls Timer**.

Recent calls

This timer displays the total number and duration of recent calls you have made and received since the last time you reset the timer.

1. Select **Menu** → **Settings** → **Call Information** → **Recent Calls Timer**.

2. Press **OK** to select **Reset**. This resets the timer to zero.

Timing your calls

If you want to know how long you are spending on a call, you can set your phone to beep 10 seconds before each minute passes.

- Select **Menu** → **Settings** → **Sounds** → **Minute Alert** → **Enabled**.

Receiving data or faxes

Your phone may be able to receive certain data or faxes, depending on the system sending the information. To receive data or faxes, you must connect the phone to a laptop or PC (see page 47), and switch the phone from voice mode to data/fax mode.

Note: You cannot receive voice calls while the phone is in data/fax mode.

1. Select **Menu** → **Settings** → **Network** → **Data/Fax Calls**.
2. Press **OK** to select an option:
 - **Voice only**—Allows only voice calls.
 - **Fax, next call**—Sets the phone to fax mode for the next incoming call or the next 10 minutes.

- **Data, next call**—Sets the phone to data mode for the next incoming call or the next 10 minutes.
- **Fax, until off**—Forces the phone into fax mode until the phone is turned off.
- **Data, until off**—Forces the phone into data mode until the phone is turned off.

Calling emergency numbers

Designating personal emergency numbers

The emergency numbers feature allows you to specify three personal phone numbers that can be called when the phone is locked.

To designate emergency numbers:

1. Select **Menu** → **Settings** → **Security**.
2. Enter your four-digit lock code. (For information on your lock code, see page 45.)
3. Select **Emergency #'s**.
4. Select an **Unassigned** slot.
5. Enter the phone number, including the area code.
Note: Do not enter 1 before the area code.
6. Press  to select **Done**.

Notes:

- You can view these numbers only when they're being entered for the first time.
- You cannot edit these numbers.
- Emergency numbers cannot be dialed using the speed dial function.
- To make a call to an emergency number from a locked phone, you must dial the number (including area code) exactly as it was stored in Emergency Numbers.
- Your phone does not enter Emergency mode when you dial an emergency number you have designated in the phone.

Calling emergency services

Note: Regardless of your 3-digit emergency code (911, 111, 000, 112, etc.), your phone will operate as described below.

- Dial your emergency code and press .

You can call the emergency code even if your phone is locked or your account is restricted. However, when you call, your phone enters **Emergency mode**. This enables the emergency service exclusive access to your phone to call you back if necessary. To make or receive regular calls

after dialing the emergency code, you must exit this mode.

Exiting emergency mode

When you have completed the emergency call:

1. Press **OK** to select Exit.
2. Press **OK** again to confirm your choice.

The phone returns to the home screen and you are ready to make and receive regular calls.

Note: To determine who has access to your location, see “Setting position location” on page 48.

Understanding roaming

Controlling network roaming

This setting allows you to force the phone into either digital or analog mode. This is useful if you are in an area that borders on digital service and the automatic feature is causing the phone to keep switching between modes.

1. Select **Menu** → **Settings** → **Network** → **Digital/Analog**.
2. Select an option and press **OK**.
 - **Automatic** automatically switches the phone between digital and analog.

- **Analog only** sets the phone to work in analog mode only.
- **Analog call** forces a call into analog mode for the duration of the next call.
- **Digital only** sets the phone to work in digital mode only.

Setting an alert for roaming

Use this setting if you want the phone to alert you when you roam outside of your home service area.

1. Select **Menu** → **Settings** → **Network** → **Roam/Svc Alert**.
2. Select an option and press **OK**.
 - **Disabled** will not alert you when you roam outside your home service area.
 - **When no svc** alerts you with three tones decreasing in pitch when service is lost and three tones increasing in pitch when service is acquired again.
 - **Roam Change** alerts you with two tones decreasing in pitch when roaming service is acquired and three tones increasing in pitch when home area service is acquired again.

- **Any Change** alerts you with three increasing tones if there is a change in roaming service or three decreasing tones if the phone loses service.

Setting the roam ringer

You can set a ringer to indicate when an incoming call will be subject to roaming charges.

1. Select **Menu** → **Settings** → **Sounds** → **Roam Ringer**.
2. Highlight **Enabled** and press **OK**. You'll hear a sample of the ringer.
3. Press **OK** to set the ringer.

Muting calls using a headset

If you are using a hands-free headset (sold separately), you can mute the current call by pressing the button on your headset cord.

3 ENTERING LETTERS, NUMBERS, AND SYMBOLS

You may enter letters, numbers, and symbols in contacts, text messages, and other functions; for example, when you create a personal banner for your phone's home screen.

For a quick reference to text entry, see page 23.

Understanding text entry screens

The text entry area is a large field in the center of the screen. The current text entry mode (and capitalization setting, when applicable) are indicated by icons at the bottom of the screen.

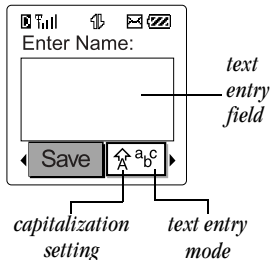

Note: Capitalization settings are discussed on page 22.

Text entry modes

There are four text entry modes:

1₂3 Number mode

a_bc Normal text mode

e_Zi Rapid text entry mode

&?! Symbol mode

Note: The mode you start in depends on the task you are doing. For example, when entering a phone number, you're in number mode. When entering a name for a contact, you're in normal text mode.

Entering numbers

You can enter numbers in several modes.

- To enter a number while in 1₂3 mode, press a number key once.
- To enter a number while in a_bc or e_Zi mode, press and hold a number key until the number appears on the screen.

a_bc Entering words letter by letter





Use normal text mode to enter letters.

1. Press a key once for the first letter, twice for the second letter, and so on.
2. Wait for the cursor to move right and enter the next letter.





Entering special characters

If your phone is set to Spanish or French, accented characters are available in normal text mode:

Spanish





	a	á	b	c	2	
	d	e	é	f	3	
	g	h	i	í	4	
	m	n	ñ	o	ó	6
	t	u	ü	ú	v	8

French

	a	à	â	b	c	ç	2	
	d	e	ë	è	é	ê	f	3
	g	h	i	ï	î	4		
	m	n	o	ô	œ	6		
	t	u	ü	ú	v	8		

eZi Entering words quickly

When you press a series of keys using eZi mode, eZi checks its dictionary of common words and guesses at the word you are trying to spell.

1. For each letter of the word you want, press the key once. For example, to enter the word “any” press:  →  →  .
2. If the word doesn't match what you want, press  to look at other word matches.
3. When you see the word you want, press  up.

eZi Personal User Dictionary

Your phone's eZi database will create a personal dictionary containing up to 400 custom words for you. If the database does not contain a word matching the sequence of keystrokes you entered, your phone will sound a single tone and display a dialog allowing you to spell and save the desired word using the a_bc text input method.



When your custom database is full, the least frequently used word is erased in favor of a new entry.

&?! Entering symbols

While entering text, you can also enter symbols by pressing  until you see the symbol you want. Using this method, you have access to the following symbols:

. & @ , - ' : ; ? / “ () _



To access the full set of symbols:

1. Press  right to highlight the current mode and press  to enter the menu.
2. Select &?! **Symbols**.
3. Press  down to view the list of symbols.
4. Press the number key corresponding to the symbol you want.

Changing modes

To enter characters that belong to a mode other than the one you're in, you'll need to change modes. For example, to enter numbers in an email address while in a_bc mode, change to 1₂3 mode, enter the number, and then change back to a_bc mode to complete the address.

To change text entry modes, you can either:



- Press and hold  until icon for the mode you want appears.
-or-
- Press  right to highlight the current text mode, press  to enter the menu, then select a different mode.

Capitalization settings

To change capitalization settings:

- Press  until the icon for the setting you want appears.













There are three capitalization settings:

This...	Capitalizes...	In mode...
	the next letter	a _b c
	every letter	a _b c , eZi
	the first letter of every <i>word</i> (in a contact) or <i>sentence</i> (in a text msg)	a _b c , eZi

Note: If no icon appears next to the text mode, all letters will be in lower case.

Quick reference to text entry

This table gives general instructions for entering letters, numbers, and symbols.

To...	Do this...
Enter a letter	Use a _b c mode and press a key until you see the letter you want. For more information, see page 20.
Enter a number	Use 1 ₂ 3 mode and press a key once to enter its number. For more options, see page 20.
Enter a symbol	Use a _b c mode and press  until you find the symbol you want. See page 22.
Enter a space	Press  .
Erase a character	Press  .
Erase all characters	Press and hold  .
Move the cursor right or left	Press  up or down.
Change text entry modes	Press and hold  .
Capitalize the next letter	In a _b c mode, press  . Choose  .
Capitalize every letter	In a _b c or eZi mode, press  . Choose  .
Capitalize the first letter of each word	In a _b c or eZi mode, press  . Choose  .
Highlight an option at the bottom of the screen	Press  left or right.

4 STORING CONTACTS

Use your phone's Contacts directory like a set of phone index cards to store information about a person or company. Your phone can hold, on average, about 200 contacts with their phone numbers and details.

Saving a phone number



To save a phone number or pager number, take these steps.

1. From the home screen, enter the phone number you want to save.
2. Press  to select **Save New**.
3. Enter a name for the contact. If you need to learn how to enter letters, see page 20.

Either save the contact now or assign options such as a speed dial number or number type.

To save now, press  to select **Save**.

-or-





To assign options, press  right, then press  to select **Options**. Press  up or down to select from the list:

- **Save**—Save the information and return to the home screen.

- **Number Type**—Select **work**, **home**, **mobile**, **pager**, or **fax**. The number type will appear as an icon next to the number in the Contacts list.
 - **Add Voice Dial**—Speak the name of the contact person for this number so that you can dial it using voice recognition (VR). For more information, see page 50.
 - **Speed Dialing**—Select a speed dialing location from the list.
 - **Secret**—Select **Yes** to lock the phone number. If a phone number is locked, you must enter your four-digit lock code (see page 45) to view or edit the number.
 - **Primary Number**—Classify this number as the primary number for the contact.
 - **Classify Contact**—Classify the contact as **Personal** or **Business**. (See page 40 to learn how to set the phone to ring differently for personal and business calls.)
4. Press  to select **Save**. A check mark and the word “Saved” appear.

Adding a code or extension

When you save the phone number of an automated service, you may include a pause where you would select an option or enter a password. You can enter multiple pauses in a phone number.

1. Enter the first portion of the phone number.
2. Press  right to scroll through the options at the bottom of the screen.
3. Press  to select a type of pause.
 -  A **Time Pause** causes the phone to stop dialing for two seconds.
 -  A **Hard Pause** causes the phone to stop dialing until you select **Release**.
4. Enter the remaining numbers.
5. Select **Save New**.

Saving an email address, street address, URL, or note



To save an email address, street address, Web page URL, or note as a new contact, follow these steps. To add one of these items to a saved contact, see “Editing or erasing a contact” on this page.

1. Select **Menu** → **Contacts** → **Add New**.
2. Highlight **Phone Number, Email Address,**

Street Address, URL, or Note and press  to select it.

3. Enter the information.
(**Tip:** To enter symbols, press and release . Repeat to cycle through symbols.)
4. Select **OK**.
5. Enter a contact name.
6. Select **Save**.

Editing or erasing a contact

1. Select **Menu** → **Contacts**.
2. Select **View All** or **Find Name** to find the contact you want to edit.
3. Highlight the contact to edit and press .
4. Select **Options**.
5. Highlight an option and press  to select it:
 - **Add New** to add a phone number, email address, street address, Web URL, or note.
 - **Erase Contact** to erase the entire contact.
 - **Edit Name** of the contact.
 - **Classify Contact** as personal or business.
6. Enter the new information.
7. If you edited the name, press  to select **Save**.

Editing a phone number

1. Select **Menu** → **Contacts**.
2. Select **View All** or **Find Name** to find the contact you want to edit.
3. Highlight the contact to edit and press **OK**.
4. Press **↓** down to highlight the phone number you want to edit and press **OK**.
5. Highlight an option for the phone number and press **OK**:
 - **Send Text Msg**—Send a text message to the phone number you selected.
 - **View Number**—See the phone number you selected.
 - **Add Voice Dial**—Speak the name of the contact person for this number so that you can dial it using voice recognition (VR). For more information, see page 50.
 - **Speed Dialing**—Select a location that you can use to speed dial the number.
 - **Edit Type**—Assign a type: **work**, **home**, **mobile**, **pager**, or **fax**. The type icon appears next to the phone number in the Contacts list.
 - **Erase Number**—Erase the number from the contact.
 - **Erase Voice Dial**—Erase the voice dial name associated with the number.
 - **Edit Number**—Change the phone number.
 - **Edit Voice Dial**—Record a new voice dial name.
 - **Secret**—Make the number secret, so that when someone opens the contact, the phone number will not appear until the lock code is entered. Secret numbers can be called, however, without a lock code. (For more information, see “Restricting calls” on page 45.)
 - **Primary Number**—Make this number the first one that shows up when you open the contact.
 - **Prepend**—Move the cursor to the beginning of the number so you can add the area code.
 - **Exit**—Exit without making changes.
6. Enter the new information and follow the prompts.
7. Press **OK** to select **Save**, if necessary.

Finding contact information

There are three main methods for finding a phone number or contact details: (1) checking the frequent contacts list, (2) searching the Contacts directory, and (3) using Fast Find.

Checking the frequent contacts list

From the home screen, press  down to see the last 15 of your most frequently called contacts, in order from most frequent to least frequent. You also see the full Contacts List if you scroll down past the double line. Note that you must enable this feature.



To enable the Frequent Contacts setting:

1. Select **Menu** → **Settings** → **Convenience** → **Frequent List**.
2. Select **Enabled**.

Tip: You can enter the first letter of the name you are looking for to skip down the list.

Searching the Contacts directory

1. Select **Menu** → **Contacts**.
2. Select a search method:
 - To view a complete list of your contacts, select **View All**.

- To locate a specific name, select **Find Name**. Enter part of the contact name, then select **Find**.
3. Scroll down to highlight the name you want.
 - To call the contact, press .
 - To access contact information, press .

Setting Fast Find

With Fast Find, you press one or two keys to view close matches of the number you are looking for.



1. From the home screen, select **Menu** → **Settings** → **Convenience** → **Fast Find**.
2. Select **Enabled**.

Using Fast Find

1. From the home screen, press the keys corresponding to the letters of the name you want to find. The matching contacts appear on the screen.









Note: Speed dial locations appear before names if they use the same keys. For example, to look for Abe's contact entry, press  for "A". Because there is a speed dial location associated with 2, the speed dial contact assigned to 2 appears first. To find Abe's

number, you would again press , the key that corresponds to the next letter of his name.

2. When you see the name you want, you can press  to call the number, or press  to view contact details.
3. If you do not see the name you want, press  up or down to search the possibilities.

Viewing contacts

The following icons may appear next to information in your Contact entries.

	work		email address
	home		street address
	mobile		Web page URL
	pager		Note
	fax		

5 SENDING AND RECEIVING TEXT MESSAGES

This chapter describes how to send, receive, and erase text messages from your phone. For information on voicemail messages, see page 14.

Important: The features and menus described in this chapter may vary depending on services available in your area. In addition, usage charges may apply to each message. For clarification on these issues, check with your service provider.

Sending text messages

Check with your service provider to find out if you are able to send text messages from your phone. You can only send text messages to phones that are capable of receiving them, or to email addresses.





Your Kyocera 3245 can provide many sending options. For example, you may:

- Send messages to group lists
- Choose from standard prewritten messages
- Create your own auto-replies
- Set message priority
- Request notification receipts

(Check with your service provider for availability of options.)

Sending a simple message

To send a plain text message to a single recipient:

1. Select **Menu** → **Messages** → **Send New**.
2. Choose a method to enter the recipient's phone number or email address:
 - Select a saved number from the **Recent List** or **Contacts List**.
 - or–
 - Enter a new address or phone number manually. Select **New Address**. To enter letters, press  right, then press  to switch to a**B**C mode. To enter “@” from a**B**C mode, press  repeatedly until the symbol appears.
 - or–
 - Select a **Group List** you have created. For more about group lists, see page 35.
3. Enter the message. To learn how to enter text, see page 20.
4. When you have completed the message, you can send it immediately or set sending options. To send it immediately, press  to select **Send**.

To set sending options, see the following procedure.



Setting sending options

When you are ready to send a message, you have several options for how and when you want the message to be received.



1. Once you have completed the message, press

 right to highlight **Options** and press

. Then choose from the list:





- **Insert**—Enhance your message with smiley faces or prewritten text.
 - **Emoticons**—Select a smiley face icon. If the recipient's phone does not support the same technology as your phone, the icons will appear to them in a more simplistic form. **Tip:** Press and hold  to cycle through emoticons while in the text entry screen. Highlight one and press  to select **Insert**.
 - **AutoText**—Select a prewritten message. Highlight one from the list and press  to select **Insert**. (To edit or create new prewritten messages, see page 36.)

- **Add Address**—Return to the “To” screen to add another recipient without losing the message text. Enter the new address, then select **Next** to return to the message entry screen.
- **Msg Receipt**—Request notification when the message has been received. (**Note:** Msg Receipt works only if the “Save to OutBox” setting is Enabled. To check this setting, see page 32.)
- **Set Priority**—Label the message as “Urgent.”
- **Callback Number**—Include a callback number with the message to let the recipient know at what number they can call you back. Select **Yes** to include your own number, or **Edit** to enter a different callback number.
- **Send Later**—Schedule when to send the message.
- **Save Message**—Save the message in your **Saved** folder. This prevents the message from being deleted if you have activated AutoErase, and enables you to send the message to others.

- **Save AutoText**—Save the message you have just entered as a prewritten message, then return to the message entry screen so you can send the message.
2. When you have finished setting options, press  to return to the message window.
 3. Highlight **Send** and press .

Sending a saved message

You can reuse a message you have stored in your **Saved** folder.

1. Select **Menu** → **Messages** → **Saved**.
2. Press  up or down through the list of messages and press  to select one.
3. Highlight an option and press :
 - **Resume**—Modify or send the message.
 - **Send To**—Add another recipient.
 - **Erase**—Erase the saved message.
 - **Done**—Return to the Saved folder.
4. When you are done entering addresses, highlight **Next** and press .
5. To send the message as it is, press  to select **Send**.

-or-

To set additional options, press  right twice, select **Options**, and choose from the options.

6. When you have finished setting options, press  to return to the message window, then select **Send**.

If you cannot send messages

You may not be able to send or receive messages if your phone's memory is nearly full, or if digital service is not available at the time. To free up memory, erase old messages. See “Erasing messages” on page 34.

Receiving incoming calls while creating messages



- If you don't wish to answer the call, select **Ignore**.
- To answer the call, press . The message you were working on will be saved in the Saved folder. To return to the message, select **Menu** → **Messages** → **Saved** and select it.

Viewing the OutBox

You can check the status of messages you have sent as long as they have been saved to the OutBox. To

check the OutBox setting, see “Saving messages to the OutBox” on page 32.

1. Select **Menu** → **Messages** → **OutBox**.
2. Press  up or down through the list of messages. One of the following symbols appears next to each message:

-
-  The message is pending and will be sent when possible. You can cancel delivery of the message.
-
-  The scheduled message will be sent at the scheduled time. You cannot cancel delivery of the message.
-
-  The message cannot be sent because service is not available. An alert appears on your phone if the message cannot be sent.
-
- The scheduled message has been sent and will be delivered as scheduled. You cannot cancel delivery of the message.
-
- The message has been received by the recipient you specified.
-
- The message has been received and opened by the recipient you specified. (This symbol may not be available. Check with your service provider.)
-



The message has been sent to more than one recipient.



The message has never been sent, or has not been sent since it was last modified. You can cancel delivery of the message.

Saving messages to the OutBox

You can have messages saved to the OutBox automatically. (This option will appear only if available from your service provider.)

Note: The OutBox is useful for checking the status of messages you have sent. Messages should be erased from the OutBox periodically to conserve memory in the phone. If you are looking for a place to save a message so that you can send it again, use the **Saved** folder. For more information, see page 30.

1. **Menu** → **Messages** → **Msg Settings** → **Save to Outbox**.
2. Select an option:
 - **Disabled**—Does not save any message to the OutBox.
 - **Prompt**—Asks you if you want to save message to the OutBox when you send the message.

- **Enabled**—Saves all sent messages to the OutBox.





Retrieving text messages

When a text message is received, your screen will display text similar to: “New message 1 Text Msg”. This text will remain for about five minutes. After that, look for the  symbol at the top of your screen. The symbol flashes if the message is urgent.

If your phone is set to Direct View, the body of the message will appear on the phone screen automatically. (To activate this setting, see page 37.)

If you see the “New Message” note

You can choose to:

- **View** the message—Press .
- **Ignore** the message—Press  right and press .
- Clear the screen—Press .

If you see the body of the message

The body of an incoming message will appear on your home screen only if your phone is set to Direct View. To set Direct View, see page 37.

You can choose to:

- **Ignore** the message—Press .

- **Read** the message. See “Reading the message” on page 33.

Note: If you receive a new message while you are reading a message, the one you are reading will be replaced by the new one. You can find the older message in the InBox: Select **Menu** → **Messages** → **InBox**.

If you see the symbol



If the  symbol is flashing, the message is urgent.

1. Select **Menu** → **Messages** → **InBox**.

A list of all your received messages appears.

New, unread messages appear in **bold**.

 indicates an “Urgent” message.

2. Press  up or down to scroll through the list of messages.
3. Press  to read a message.

Reading the message

The options available to you may vary. Check with your service provider.

1. If the text message is long, press  down to view the entire message.
2. When you are finished, you can **Reply** to the sender, **Erase** the message, **Save** the message to

your Saved folder, or set additional **Options** for the message:

- View **Sender** information.
- **Forward** the message.
- **Reply with Copy** to reply to the message with a copy of the original attached.
- **Save as AutoText** to save the text from the message as AutoText, which you can insert into other messages. (For more about AutoText, see page 36.)
- **Block** (This option will appear only if available from your service provider.) Block the sender's address so that your phone will not receive any more messages from it.

3. Select **Done**.

Setting message alerts





You can set your phone to alert you of incoming text messages or pages. For more information, see “Setting message alerts” on page 46.

Erasing messages

Your phone is designed to store 99 text messages and pages. It is a good idea to erase old messages, as messages take up memory in your phone.



You have the option of erasing text messages and pages as you send or read them, erasing them one-at-a-time from the list in the OutBox or InBox, or erasing them all at once.

Erasing single messages

1. Select **Menu** → **Messages**.
2. Press  down and press  to select the type of text message you want to erase (**InBox**, **OutBox**, or **Saved**).
3. Press  to select the message to erase.
4. Press  right twice and select **Erase** to erase the message. A notification appears: “Erase this message?”
5. Select **Yes** to erase the message.

Note: You can erase a scheduled message from the OutBox, but you cannot cancel delivery of the message.

Erasing all messages

1. Select **Menu** → **Messages** → **Erase Msgs.**
2. Press  up or down and press  to select an option:
 - **InBox** erases all messages in your InBox.
 - **OutBox** erases all messages in your OutBox.
 - **Saved Folder** erases all messages in your Saved folder.
 - **All Messages** erases all text messages in all folders listed above.
3. A message appears: “Erase all messages?”
Select **Yes** to erase messages or **No** to cancel.

Erasing messages automatically

Use this setting to have old messages automatically erased from the InBox when memory is low.





1. Select **Menu** → **Messages** → **Msg Settings** → **Auto-Erase.**
2. Select **Old InBox Msgs** and press .

Customizing message settings

To make messaging easier, you can customize settings for sending and receiving messages.





Creating group lists

You can create and save a list of multiple recipients. Your Kyocera 3245 phone will store five group lists with up to 10 recipients per list.

1. Select **Menu** → **Messages** → **Group Lists** → **Create New.**
2. Enter a name for the list. For help entering text, see page 20.
3. Press  to select **Next.**
4. To enter the first phone number or email address, select an option:
 - **Recent List**—Select numbers from your Recent List. Highlight the number or contact name and press . The phone number appears in the address field.
-or-
 - **New Address**—Enter the phone number or email address yourself. To enter letters, press  to switch to a_bc mode. To enter symbols, press  until you find

the symbol you want. For more information on text entry modes, see page 20.

-or-

- **Contacts List**—Select contacts from your phone book. Highlight the contact and press  twice. The phone number appears in the address field.
- 5. To enter the next address, enter a space or comma after the first number or email address. (If you insert a saved contact or a number from the Recent List, the phone will insert the comma automatically.) Then press  right twice, select **Options**, and choose from the options.
- 6. Press  right and press  to select **Done**.
- 7. To send a message to your new group, see “Sending text messages” on page 29.

Creating and editing prewritten messages (AutoText)

Your phone comes with prewritten (AutoText) messages, such as “Please call me,” which you can insert into the body of a text message. You can edit these messages and create new ones. Your phone

will store up to 20 AutoText messages, with up to 100 characters per message.

1. Select **Menu** → **Messages** → **Msg Settings** → **Edit AutoText**.
2. To create a new pre-written message, highlight **New AutoText** and press .

-or-

To edit an existing pre-written message, highlight the message and press .

3. Enter or edit the text and press  to select **Done**. For help entering text, see page 20.

Note: You can also save an incoming message as AutoText. For directions, see page 34.

Creating a signature

You can create a signature that will be added to the end of your outgoing messages. (This option will appear only if available from your service provider.)

1. Select **Menu** → **Messages** → **Msg Settings** → **Signature**.
2. Enter the signature text.
3. Press  to select **OK**.

The signature is now included on all of your outgoing text messages. You will not see the signature on the message screen.

Note: The signature is counted into your maximum character limit of 100.

Erasing or editing a signature

1. Select **Menu** → **Messages** → **Msg Settings** → **Signature**.
2. Edit or erase the text.
3. Press  to select **OK**.

Switching default text entry mode

You can set the default text entry mode for text messaging.

1. Select **Menu** → **Messages** → **Msg Settings** → **Default Text**.
2. Select **Normal Alpha** or **Rapid Mode**.

For more information on text entry modes, see page 20.

Having messages open automatically (Direct View)

With Direct View, you can set your phone to open incoming text messages and display them on the home screen as soon as the phone receives them.

Note: Messages will not appear on the screen if the phone is in use.

1. Select **Menu** → **Messages** → **Msg Settings** → **Direct View**.
2. Select **Enabled**.

6 CUSTOMIZING YOUR PHONE

The contents of the **Settings** menu are as follows.

Silent Mode

Keyguard

Sounds

Ringer Volume

Ringer Type

Business Ring

Personal Ring

Roam Ringer

Earpiece Volume

Key Volume

Key Length

Missed Call

Smart Sound

Minute Alert

Spkrphone Vol.

Display

Backlighting

My Banner

Flashing Lights

Main Menu View

Display (Con't)

Screen Saver

Auto-Hyphen

Language

Time Format

Contrast

Voice Services

Add Voice Dial

Erase Voice Dial

Voice Training

Voice Wake-Up

Voice Answer

Expert Mode

Security

Lock Phone

Limit Calls Out

Lock Code

Erase Contacts

Emergency #'s

Call Information

Recent Calls Timer

All Calls Timer

Browser Timer*

Network

Data/Fax Calls

Privacy Alert

Set Phone Line

Roam/Svc Alert

Roam Option

Digital/Analog

Location

Convenience

Shortcut Key

Fast Find

Frequent List

Hold Call

1-Touch Dialing

Web Prompt

Messaging

Voicemail Num.

Alerts

Signature*

Edit AutoText

Msg Receipt

Callback Number

Direct View

Save to Outbox*

Auto-Erase

Default Text

Accessories

Pwr Backlight

Headset Ring



Auto-Answer

Com Speed

* This option will only appear if available from your service provider.

Setting vibrate mode

You can set your phone to vibrate or to vibrate and then ring when you receive an incoming call.

1. Select **Menu** → **Settings** → **Silent Mode**.
2. Choose an option and press :
 - **Vibrate Only**—Causes the phone to vibrate for the duration of the incoming call alert.
 - **Vibe then Ring**—Causes the phone to vibrate for the first 10 seconds and then ring for the remainder of the incoming call alert.
 - **Lights Only**—Causes the screen and keys to light up and flash for the duration of the call alert.
 - **Normal Sounds**—Turns off silent mode.
3. Press  to return to the home screen.



Note: The phone will ring when attached to an external power source (such as a charger), even if vibrate mode has been activated.

Silencing all sounds

Your phone is set to ring for incoming calls and to beep to indicate alerts (such as new messages) and movement through the menus.



There is a quick way to silence all sounds and set your phone to vibrate and light up to indicate incoming calls and alerts.

To silence all sounds

- From the home screen, press  right and hold.
A  appears on the screen, indicating the phone has silenced all sounds and is in vibrate mode.

Note: The phone will ring when it is attached to an external power source (such as a charger), even when all sounds have been silenced.

Specifying just vibration or just lights

1. Select **Menu** → **Settings** → **Silent Mode**.
2. Select **Vibrate Only** or **Lights Only**.
A  indicates vibrate mode, and a  indicates lights-only mode.
3. Press  to save your selection.

Turning sounds back on

- The quickest way to turn sounds back on is to press  right and hold.

You can also use menus:

1. Select **Menu** → **Settings** → **Silent Mode**.
2. Select **Normal Sounds**.

3. Press  to save your selection.

Choosing a different ringer

Your Kyocera 3245 phone has 25 ringers you can choose from for your incoming calls.

1. Select **Menu** → **Settings** → **Sounds** → **Ringer Type**.
2. Scroll down the list to hear the different rings.
3. Press  to select a ringer from the list.

Specifying ringers for different calls

You can set up your phone to ring differently for calls from phone numbers classified as business or personal contacts.

1. If you have not already done so, save the contact in your Contacts directory and classify it as business or personal. For help, see page 24.
2. Select **Menu** → **Settings** → **Sounds** → **Business Ring** or **Personal Ring**.
3. Select a ringer from the list.

Importing additional ringers

You can import additional ringers into your Kyocera 3245 phone using the Kyocera Phone Desktop software (sold separately). To purchase

this software and other accessories, visit www.kyocera-wireless.com/store.

You may be able to download ringers over-the-air. Check with your service provider for availability.

Adjusting volume

You can adjust the volume of the earpiece, the ringer, the speakerphone, or the beeps you hear when the keys are pressed.

Adjusting the earpiece volume



To adjust the earpiece volume manually during a call, press  up or down to find a comfortable level.

Adjusting the ringer volume

1. Select **Menu** → **Settings** → **Sounds** → **Ringer Volume**.
2. Press  right to increase the volume, or left to decrease the volume.

Adjusting the speakerphone volume

To adjust the speaker volume:

1. Select **Menu** → **Settings** → **Sounds** → **Spkrphone Vol**.
2. Press .
3. Press  up or down to find the level.

4. Press  to save the setting.

Changing the key tones

You can change the volume and duration of the tones the phone makes when you press the keys. Select **Menu** → **Settings** → **Sounds** and choose **Key Volume** or **Key Length**.

Using shortcuts

From the home screen, you can access shortcuts by pressing the navigation key in different directions.

Three shortcuts are automatically programmed into your phone (left, right, and down). For the fourth direction (up), you can set a shortcut to one of the features of your phone.

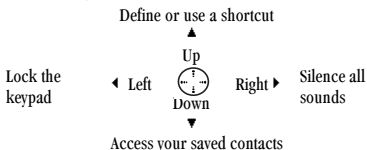

Defining the “up” feature shortcut

When you define a feature shortcut, you are able to bypass the menu selection and scrolling and need only press  up to launch the screen of the function you choose.

1. Select **Menu** → **Settings** → **Convenience** → **Shortcut Key**.
2. Highlight the feature you want a shortcut to, and press  to select it:
 - InBox
 - Send New Msg
 - Ringer Volume
 - Recent Calls
 - Business List
 - Personal List
 - Web Browser (*This option will only appear if available from your service provider.*)
 - Stopwatch
 - Calculator
 - Voice Memo
 - Scheduler
 - **None** to disable this shortcut

Using the up feature shortcut

- From the home screen, press and hold  up.

Creating a shortcut to your frequent contacts list

By default, your phone lists your entire contacts list when you press  down. You can set the phone also to show a list of your most frequent contacts.

1. Select **Menu** → **Settings** → **Convenience** → **Frequent List**.
2. Select **Enabled** to include the list or **Disabled** to remove it.

Using the Frequent Contacts shortcut

- From the home screen, press  down. The Frequent Contacts appear at the top of the list, followed by your complete Contacts List.

Personalizing the screen

Changing your banner

The banner is the personal label for your phone. It appears on the home screen above the time and date. The banner can be up to 14 characters long.

1. Select **Menu** → **Settings** → **Display** → **My Banner**.
2. Select **Edit**.
3. Press  to clear the screen.



4. Enter your new text.
5. Press  to save.

Setting a screen saver

Several screen savers are provided with your phone. A screen saver works only from the home screen, and activates 10 seconds after the last keypress. Incoming calls and alerts override screen savers.

Note: Voice services will not work when a screen saver is activated.

To activate a screen saver:

1. Select **Menu** → **Settings** → **Display** → **Screen Saver**.
2. Highlight a screen saver name and press .
3. Press  to return to the home screen and wait 10 seconds to view the screen saver you chose.

Note: You can add graphics you have created or saved to the Screen Savers list. Refer to See “My Pictures” on page 67.

Choosing a different time/date format

1. Select **Menu** → **Settings** → **Display** → **Time Format**.

2. Highlight the option you want.

Choosing a different menu view

You can change the appearance of the menus you see when you select **Menu** from the home screen.

1. Select **Menu** → **Settings** → **Display** → **Main Menu View**, then the option you want:



Graphics

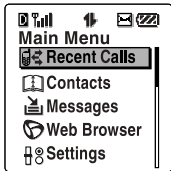

List

2. Press **END** to return to the home screen. The next time you press **OK**, you will see the menu view you selected.

Adjusting the backlighting

Your screen lights up while you are in a call or when you press a key on the keypad. However, you can change when and how backlighting lights up.

1. Select **Menu** → **Settings** → **Display** → **Backlighting**.

2. Select an option from the list:

- **Disabled**—Turns backlighting off.
- **5 seconds**—(Default) Turns backlighting on for 5 seconds after your last keypress.
- **10 seconds**—Turns backlighting on for 10 seconds after your last keypress.
- **30 seconds**—Turns backlighting on for 30 seconds after your last keypress.
- **5 sec. & in call**—Turns backlighting on during a call, and for 5 seconds after your last keypress.
- **10 sec. & in call**—Turns backlighting on during a call, and for 10 seconds after your last keypress.
- **30 sec. & in call**—Turns backlighting on during a call, and for 30 seconds after your last keypress.

Note: Keeping backlighting on during a call drains the battery more quickly and reduces talk and standby times.

Setting power backlighting

You can set backlighting to remain on when an external power source, such as the AC adapter, is used with the phone.

Note: Power backlighting may not be available with some accessories. Check with your service provider.

1. Select **Menu** → **Settings** → **Accessories** → **Pwr Backlight**.
2. Select **Always On** to keep backlighting on. (The battery charges more slowly when power backlighting is on.)

Setting flashing lights

You can set the backlighting on your phone to flash when an incoming call is received. Even if you silence the ringer, the lights will still flash.

1. Select **Menu** → **Settings** → **Display** → **Flashing Lights**.
2. Select from **Fast Flash**, **Slow Flash**, or **Heartbeat**. As you highlight the options a sample of the flash each emits is provided.
3. Press **OK** to select your option.

Caution: A small percentage of users may be photo sensitive to flashing lights. In rare cases, exposure to flashing lights, under certain circumstances, may produce seizures. While such an event is not known to occur with mobile phone use, and the Kyocera 3245 phone has been designed to minimize the possibility of any such occurrence, those who

believe they may be photo sensitive should not enable the flashing lights feature.

Changing the display contrast

1. Select **Menu** → **Settings** → **Display** → **Contrast**.
2. Select the level of contrast you want (**Highest**, **High**, **Medium**, **Low**, and **Lowest**).

Setting numbers to auto-hyphenate

Auto-hyphenation is a setting that automatically inserts hyphens into your phone numbers to be consistent with the U.S. dialing plan. For example, 1-222-333-4444.

- Select **Menu** → **Settings** → **Display** → **Auto-Hyphen** → **Enabled**.

Choosing a different language

Your phone may support languages in addition to English.

1. Select **Menu** → **Settings** → **Display** → **Language**.
2. Select a language, and press **OK**.
3. To enter special characters for languages other than English, see “Entering special characters” on page 21.

Creating a secure environment

This section describes all the features involved in securing your phone and preventing access to personal information. All security features are shielded by a four-digit lock code.

Changing your lock code

The lock code is typically 0000 or the last 4 digits of your phone number.

1. Select **Menu** → **Settings** → **Security**.
2. Enter your four-digit lock code and select **Lock Code**. A message appears: “Change Code?”
3. Select **Yes**, enter a new four-digit code, then press **OK**. Enter your new lock code again.

Locking your phone

When your phone is locked, you can call only emergency numbers or your service provider number. You can still receive incoming calls.

1. Select **Menu** → **Settings** → **Security**.
2. Enter your four-digit lock code.
3. Select **Lock Phone**.
4. Highlight an option:

- **Never**—Does not lock the phone.
- **On power up**—Locks the phone every time you turn it on.
- **Now**—Locks the phone immediately.

5. Press **OK**.

Unlocking the phone

1. From the home screen, press **OK** to select **Unlock**.
2. Enter your four-digit lock code.

Restricting calls



You can restrict the calls that can be made from your phone to only those that have been saved in your Contacts Directory.

1. Select **Menu** → **Settings** → **Security**.
2. Enter your four-digit lock code.
3. Select **Limit Calls Out**.
4. Select **Contacts Only**.

Erasing all contacts





You can erase all contacts from the Contacts directory.

1. Select **Menu** → **Settings** → **Security**.
2. Enter your four-digit lock code.

3. Select **Erase Contacts**.
4. Select **Yes** to erase all contacts. A message appears: “Erase ALL contacts?”
5. To erase all contacts, press  right to highlight **Yes** and press .

Setting message alerts

You can choose how you want be alerted of incoming voicemail, pages, or text messages.

1. Select **Menu** → **Settings** → **Messaging** → **Alerts**.
2. Select the type of alert: **Message, Net, Page, or Voicemail**.
3. Press  to select an option:
 - **Disabled**—Does not alert you when a message is received.
 - **Vibrate Once**—Sets the phone to vibrate once when a new message is received.
 - **Vibe & Remind**—Sets the phone to vibrate once when a new message is first received, and once every five minutes. To stop the reminder, press  to select **Ignore**.
 - **One Soft Beep**—Sets the phone to beep once softly when a message is received.
 - **Soft Beeps**—Sets the phone to beep softly approximately every five minutes. To stop this reminder, press  to select **Ignore**.
 - **One Loud Beep**—Sets the phone to beep once loudly when a message is received.
 - **Loud Beeps**—Sets the phone to beep loudly approximately every five minutes. To stop this reminder, press  to select **Ignore**.

Setting alerts for your headset

When a headset (sold separately) is attached to the phone, you can set alert sounds to originate from the headset.

1. Select **Menu** → **Settings** → **Accessories** → **Headset Ring**.
2. Select **Out of headset** to have alerts originate from the headset.

Switching between phone lines

Your phone can have two service accounts, or phone lines, associated with it. Each phone line has its own phone number. When you are using one line, you cannot receive calls from the other.

It would be as if the phone were “off” for that number. Your voicemail, however, will still take messages. All contacts and settings are shared for both lines.

1. Select **Menu** → **Settings** → **Network** → **Set Phone Line**.
2. Select the other line and press .

Note: Once a second phone line is established, a second phone number becomes available for selection.

Data settings

Connecting to a laptop or a PC







The Com Speed sets the data rate at which your phone connects to a laptop or PC, or at which it sends and receives over-the-air text messages.

1. Select **Menu** → **Settings** → **Accessories** → **Com Speed**.
2. Select the speed. The options are: **19.2 kbps**, **115.2 kbps** (default), **230.4 kbps**.

Note: There may be a higher charge for making calls using high-speed data in areas where 1X service is available. Check with your service provider for details.

Connecting to a TTY/TDD device

You can connect the phone to a TTY device for the hearing impaired.

1. Connect the TTY device to the phone.
2. Enter      from your keypad.
3. Press  to select the **TTY** option.

Note: Enable TTY only when using the phone with a TTY device.

Setting the phone to receive data or faxes

Your phone may be able to receive certain data or faxes, depending on the system sending the information. To receive data or faxes, you must connect the phone to a laptop or PC and switch the phone from voice mode to data/fax mode.

Note: To purchase a cable, you can contact your service provider or purchase one from us at (800) 349-4188 (U.S.A. only) or (858) 882-1410, or online at www.kyocera-wireless.com/store.

1. Connect the phone to the laptop or PC.
2. Set the Com Speed. (See “Connecting to a laptop or a PC” on this page.)

3. Select **Menu** → **Settings** → **Network** → **Data/Fax Calls**.
4. Press **OK** to select an option:
 - **Voice only**—Allow only voice calls.
 - **Fax, next call**—Set the phone to fax mode for the next incoming call or the next 10 minutes.
 - **Data, next call**—Set the phone to data mode for the next incoming call or the next 10 minutes.
 - **Fax, until off**—Force the phone into fax mode until the phone is turned off.
 - **Data, until off**—Force the phone into data mode until the phone is turned off.

Note: You cannot receive voice calls while the phone is in data/fax mode.

Setting position location

This setting allows you to share your location information with network services other than emergency services, such as 911, in markets where service has been implemented.

Note: This feature works only when your phone is in digital mode. You do not have the option of turning off the locator to emergency services.

To set your option:

1. Select **Menu** → **Settings** → **Network** → **Location**.
2. If you see a message prompt, press **OK** to continue.
3. Select **911 Only** or **Location On**.
 - **911 Only** (default) shares your position information only with emergency services when making a 911 call.
 - **Location On** shares your position information with your service provider's network, in addition to emergency services.

For information on emergency calls, see “Calling emergency services” on page 17.

7 USING VOICE RECOGNITION

Voice recognition is a unique feature on your Kyocera 3245 phone that allows you to make and answer calls by speaking commands into the phone's microphone.

Note: You cannot use voice recognition to end a call; you must press .

Setting up voice dialing

To make or receive calls using voice recognition (voice dialing), contacts must be saved and have associated voice commands, or *voice tags*.

Adding a voice tag before choosing the contact





This procedure allows you to record a voice tag before creating a new contact or assigning it to a contact.

1. Select **Menu** → **Contacts** → **Add Voice Dial**.
2. Follow the voice prompts to record a name for the contact.
3. Highlight an option:
 - **Add new**—Save a new contact to go with the voice tag.

- **Add to existing**—Add the voice tag to a saved contact.

Adding a voice tag to a new contact

This procedure allows you to create a contact before adding a voice tag to it.

1. From the home screen, enter the phone number of the person you want to call.
2. Press  to select **Save New**.
3. Enter a name for the contact. For help entering letters, see page 20.
4. Press  right twice and select **Options**.
5. Select **Add Voice Dial**.
6. At the tone or prompt, say a name, then repeat the name as instructed. You hear “(Name) added” or, if the name was not saved, you are instructed to try again.
7. Scroll up to **Save** and press .
8. Press  to return to the home screen. You are now ready to make a call using this voice tag. See page 50.

Adding a voice tag to an existing contact

This procedure allows you to choose a contact from your list before adding a voice tag to it.

1. From the home screen, select **Menu** → **Contacts** → **View All**.
2. Highlight the contact you want to add voice tag to and press **OK**.
3. Highlight the phone number and press **OK**.
4. Select **Add Voice Dial**.
5. Follow the prompts to record a name.
6. Press **end** to return to the home screen.
You are now ready to make a call using this voice tag.

Viewing entries with voice tags

- Select **Menu** → **Contacts** → **Voice Dial List**.
A list of all contacts with assigned voice tags appears.

Editing a voice tag

1. Select **Menu** → **Contacts** → **Voice Dial List**.
2. Highlight the contact you want to edit, and press **OK** to select it.

3. Highlight the phone number and press **OK**.
4. Select **Add Voice Dial**, **Edit Voice Dial**, or **Erase Voice Dial**.
5. Follow the prompts.

Calling using voice tags

1. If you haven't already done so, record a voice tag for the person you wish to call. See "Setting up voice dialing" on page 49.
2. From the home screen, press **talk**.
The phone responds: "Say a name or say dial."
3. Say the name of the person you want to call.
4. If the name you said matches a contact in the Voice Dial List, the phone responds: "Calling (Name)." Remain silent to make the call, or say "**No**" to cancel.

Note: If there are multiple names saved in the Voice Dial List that match the name you said, you will be asked to verify which name you want to call. Say "**Yes**" when you hear the correct name. Say "**No**" when you hear an incorrect name.

5. When you are finished, press **end**.
You cannot end the call with a voice command.

Making calls using expert mode

Expert Mode substitutes tones for some of voice prompts to allow the experienced user to quickly complete certain tasks without having to listen/wait for a voice prompt.

To enable Expert Mode:

1. Select **Menu** → **Settings** → **Voice Services** → **Expert Mode**.
2. Select **Expert**.

To make a call in Expert Mode:

1. Press  and wait for the beep.
2. Say the name or the speed dial number of the contact you want to call.

Making calls using digit dialing

When using digit dialing, you speak digits to dial a phone number.

Note: If you are speaking digits in a language other than English, you will first need to train the phone to recognize your voice. See “Training voice recognition” on page 53.

1. From the home screen, press .
The phone responds: “Say a name or say Dial.”
2. Say “**Dial**.” The phone responds: “Speak a digit.”

3. Speak the first digit of the phone number you want to call. Once the phone repeats the digit, you can speak the next digit.

Note: You cannot speak a string of digits. You must speak one digit at a time and wait for the prompt.

If you pause, the phone will prompt you with the following five options. After the prompt, speak an option.

- Say “**Clear**” to erase the digit last entered. The phone responds: “Digit cleared.” To clear the entire phone number, say “**Clear**” again. When the phone prompts you with “Clear entire phone number?”, say “**Yes**” to clear or “**No**” to cancel.
- Say “**Call**” to dial the number.
- Say “**Verify**” to cause phone to repeat the set of digits that you input.
- Say “**Cancel**” to exit voice recognizer and return to the home screen.
- Speak a digit to enter the next digit. Once the phone repeats the digit, you can speak the next digit or pause to hear the prompt.

Using voice features with accessories

You can use voice commands to make a phone call, answer the phone, or ignore an incoming call only if your phone is connected to an accessory such as a hands-free car kit or headset (both sold separately).

To shop online for a hands-free car kit or headset, visit www.kyocera-wireless.com/store. To order by phone, call (800) 349-4188 (U.S.A. only) or (858) 882-1410.

Waking up the phone

The Voice Wake-up feature allows you to use a voice command to activate the phone to make a phone call if your phone is connected to a hands-free car kit or headset.

Note: Voice Wake-up does not work with Keyguard active.

To activate the Voice Wake-up setting:

1. Select **Menu** → **Settings** → **Voice Services** → **Voice Wake-Up** → **With ext. pwr.**
2. Select **Menu** → **Settings** → **Keyguard** → **Disabled**, then press .

To wake up the phone:

1. Say **“Wake Up”** and listen for a tone.
2. Say **“Wake Up”** again until you hear two tones.

If the phone does not recognize your “Wake up” command, see “Training voice recognition” on page 53.

Answering the phone

You can set the hands-free car kit to do one of the following:

- Ring until you press a key or answer using a voice command
- Automatically answer the phone after 5 seconds

Answering automatically

To set your hands-free car to answer the phone automatically after 5 seconds:

1. Select **Menu** → **Settings** → **Accessories** → **Auto-Answer**.
2. Select **After 5 secs.**

Answering using voice commands

You can use a voice command to answer an incoming call if your phone is connected to a

hands-free car kit or headset and Auto-Answer is turned off:

1. Select **Menu** → **Settings** → **Accessories** → **Auto-Answer**.
2. Select **Disabled**.

To activate the Voice Answer setting:

1. Select **Menu** → **Settings** → **Voice Services** → **Voice Answer**.
2. Highlight **Enabled**, then press **OK**.
3. Select **Menu** → **Settings** → **Silent Mode** → **Normal Sounds**, then press **OK**.

To answer a call:

When you receive an incoming call, the phone responds: “Incoming call, answer?” or “Incoming roam call, answer?” If the caller is recognized as a contact entry in your phone, then the phone will say “Incoming call from (Name), answer?”

- Say **“Yes”** or press any key *except* the end key.

Training voice recognition

If your phone is having trouble recognizing your voice, you can train it with standard commands.

1. Select **Menu** → **Settings** → **Voice Services**.
2. Select **Voice Training**.

3. Read the message and press **OK**.
4. Select **Train All**.
5. Follow the prompts for each word until training is complete.

Note: The “Wake up” command can only be used with a hands-free car kit or headset (both sold separately). See page 52.

Ignoring an incoming call

To ignore an incoming call, do one of the following:

- Say **“No”** and press **end** to silence the alert.
- Remain silent. The voice alert repeats twice and the phone rings once, then returns to the home screen.

Using the Web Browser

You can use your phone to browse the Internet if you have obtained phone Internet services from your service provider and if over-the-air Internet access is available in your area.

Note: You cannot receive incoming calls while you are using the Web Browser.

Starting the Web Browser

1. Select **Menu** → **Web Browser**.

A message informs you that airtime fees apply for browser use. For more information about how airtime is charged, contact your service provider.

Note: If you wish to cancel this message prompt, see “Changing the Web prompt” on page 56.





2. Press  to continue.

If this is the first time you have connected to the Internet, a message informs you that security is not yet enabled for your Web Browser.

3. Press  to select **Yes** to enable security.

When you are connected to the Web Browser, a browser home page will appear. It has a list of bookmarks and some Web menu options at the bottom of the screen.

Notes:

- A  appears in a secure session.
 - An underline and an arrow indicate that there is more text. Press  down to view more text. Press  to return to the previous screen.
 - For information on the menu options at the bottom of the screen, see “Using the Web menu options” on page 54.
 - For help searching for a Web site, see “Searching for a Web site” on page 55.
4. When you have finished using the Internet, press  to exit the browser.

Using the Web menu options

The following options may appear on your screen:

- **Home** returns you to the main Web Browser window, or home page.

- **Mark Site** saves the current location as a bookmark for easy access.
- **Bookmarks** displays a list of your saved Web sites.
- **Setup** gives you options for changing how information is displayed.
 - **Show URL** displays the entire URL.
 - **About Openwave** displays information about your Web Browser version.
 - **Encryption** should not be used unless you are instructed to do so by your service provider.
 - **UP.Link** selects a different browser server. You can use this option if you have more than one Web Browser account, such as one for business and one for personal use.
 - **Restart** restarts the Web Browser.

Searching for a Web site



How you search for a Web site depends on your service provider. However, most providers place search engines on the home page. For more information about searching for a Web site, contact your service provider.

Bookmarking a Web site

When you have found a Web site that you want to access quickly, you can bookmark it so that it will be easily accessible from the home page.

1. Go to the site you would like to bookmark.
2. Ensure that you are looking at the actual page you would like to access.
3. Select **Mark Site** from the bottom of the screen.

Going to a bookmarked site

1. Select **Menu** → **Web Browser**.
2. If you see a message prompt, press  to continue.
3. From your Web home page, press  right to highlight **Bookmarks**.
A list of bookmarks appears.
4. Enter the number corresponding to the bookmark you want and press .

Checking Net alerts

When alerts are received from a Web site, they are sent to your **Net Alerts** inbox.

1. Select **Menu** → **Messages** → **Net Alerts**. This action launches the browser inbox.
2. Press **OK** to accept browser fees.
3. Select the alert you want to read, and follow the prompts.

Keeping track of browser usage

Your phone has a timer that counts the number and total duration of Web calls you have made since the last time you reset the timer.

- Select **Menu** → **Settings** → **Call Information** → **Browser Timer**.
- If you want to reset the timer to zero, select **Reset**.

Note: A single browser session may consist of several browser calls.

Changing the Web prompt

You can choose to receive a confirmation prompt whenever you start or exit the Web Browser.

1. Select **Menu** → **Settings** → **Convenience** → **Web Prompt**.

2. Highlight an option and press **OK** to select it:
 - **At Start** confirms that airtime fees will be applied when you use the browser.
 - **At End** verifies you want to exit the browser.
 - **Both** prompts you when you start the browser and exit the browser.
 - **No Prompts** does not use any prompts.





9 USING TOOLS

Voice Memo



The Voice Memo tool allows you to record and play back audio memos.

Shortcut: You can access voice memo quickly by setting up a shortcut. See “Defining the “up” feature shortcut” on page 41.

Functions

	Play		Fast forward
	Pause	NAME	Name the memo
	Stop	ERASE	Erase a memo
	Rewind		



Recording a voice memo

1. Select **Menu** → **Tools** → **Voice Memo** → **Record New**.
The phone says: “Please record at the tone.”
2. Say your memo and select  when finished.
 - To review your recording, press .



- To save a name for your memo, press  right and select **Name**. You may enter up to 12 characters. Memos saved without names are saved as “Memo 1”, “Memo 2”, etc.

3. Press  to select **Save**.



Playing a voice memo

1. Select **Menu** → **Tools** → **Voice Memo**.
2. Highlight the memo you want to hear.
3. Press .
4. Highlight  and press .

Rewind and fast forward

To rewind or fast forward a voice memo while it is playing, select  to rewind or  to fast forward.

Naming a saved voice memo

1. Select **Menu** → **Tools** → **Voice Memo**.
2. Highlight the memo and press .
3. Press  right to highlight **Name**.
4. Press  and follow the prompts.

Erasing a saved voice memo

1. Select **Menu** → **Tools** → **Voice Memo**.
2. Highlight the memo and press **OK**.
3. Press **⏮** right to highlight **Erase**.
4. Press **OK** and follow the prompts.

Scheduler

The Scheduler allows you to schedule events, such as meetings or appointments, and keep track of annual occasions, such as birthdays or wedding anniversaries.

Adding an event

Events are placed on the calendar at the time you select.





1. Select **Menu** → **Tools** → **Scheduler**.
2. Find the day for the event and press **OK**.
 - For a day in this month, select **View Day**. Press **⏮** left and right to scroll through days.
 - For a day in a different month, select **View Month**. Press **⏮** up or down to scroll through months, and right or left to scroll through days.

3. Select **Add Event** and press **OK**.
4. Enter a name for the event. For help entering text, see page 20.
5. Press **OK** when you are done entering letters.
6. Select **Next** to set the event Start time, Duration, and Alarm.
 - Press **⏮** up or down to select hour, minutes, and timing of alarm.
 - Press **⏮** left or right to move between fields.
7. Press **OK** to select **Next**.
8. Add a note to the event and press **OK** or press **OK** twice to finish.







Adding an occasion

Occasions are placed on the calendar at the beginning of the day you select. If you set the alarm for an occasion to alert you on “Day of,” the alarm will go off at the beginning of the day.







1. Select **Menu** → **Tools** → **Scheduler** → **Add Occasion**.
2. Enter a name for the occasion or add a name from the Contacts list. For help entering text, see page 20.

3. Press  when you are done entering letters.
4. Select **Next** to set the occasion Date, Type, and Reminder.
 - Press  up or down to select month, date, year, occasion type, and timing of reminder.
 - Press  right or left to move between fields.
5. Press  to add the occasion.

Viewing, editing, or erasing an event



1. Select **Menu** → **Tools** → **Scheduler**.
2. Select **View Day** or **View Month** to find the event you want to view, edit, or erase.
3. Press  up, down, left, or right to highlight an event and press  to select it.
4. Press  right and press  to select **Edit**, **Erase**, or **New**. Follow the prompts.
5. Press  to return to the home screen or  to return to scheduler options.

Viewing a list of occasions

1. Select **Menu** → **Tools** → **Scheduler** → **View Occasions**.
2. Press  up or down to highlight an occasion and press  to select it.
3. Press  right and press  to select **OK**, **Edit**, or **Erase**. Follow the prompts.
4. Press  to return to the home screen or  to return to scheduler options.







Alarm Clock

Use the Alarm Clock to set an alert for a specific time. The alert occurs only if the phone is on.

1. Select **Menu** → **Tools** → **Alarm Clock** → **Set**.
 - Press  up or down to select an hour and minutes.
 - Press  left or right to switch between hours, minutes, and a.m./p.m.
 - Use the phone keypad to enter numbers.
2. Press  to select **Done** and save the setting.
3. When the alarm rings, select **Off** to turn off the alarm or **Snooze** to silence the alarm for 10 minutes.

Tip Calculator

The Tip Calculator helps you calculate how much tip to include on a bill.

1. Select **Menu** → **Tools** → **Tip Calculator**.
2. Enter the amount of your bill and press .
3. Select the amount you want to include as a tip (10%, 15%, 18%, 20%, Other) and press . Your total bill appears, including tip.
4. If you want to split the bill, press  right and press  to select **Split**.
5. Press  to clear the default of 2 guests.
6. Enter the number of guests and press .
The amount each guest pays is calculated.

Calculator

Use the calculator for basic mathematical equations.

1. Select **Menu** → **Tools** → **Calculator**.
2. Use the keypad to enter numbers.
3. Press  to select mathematical operations.

= equal + add × multiply
÷ divide - subtract . decimal point

C Clear all numbers entered and display a zero.

MR Display the value currently stored in memory.

M+ Add the displayed digit to the value stored in memory.





MC Clear the value currently stored in memory.
± Change the sign of the displayed number.

 Clear one function or one digit from the screen and return the calculator to digit entry mode. Hold down to clear all of the digits and operations and display a zero.

 Exit the calculator and return to home screen.

Timer

This timer counts down for a specified amount of time. It beeps when that amount of time has elapsed.

1. Select **Menu** → **Tools** → **Timer**.
2. Press  to **Set**.
3. Press  up or down to set the hours, minutes, and seconds. To move the cursor, press  left or right.
4. Select **Start** to begin the countdown.
Select **Stop** to pause the countdown.
5. When the alarm rings, press  to silence it.

Stopwatch

1. Select **Menu** → **Tools** → **Stopwatch**.
2. Select **Start** to have the stopwatch begin counting.
3. Select **Stop** to stop counting.
4. Select **Reset** to set the counter back to zero and begin counting again.
Press  when finished.

10 FUN & GAMES

Your Kyocera 3245 phone comes with games, a doodler, and storage for downloaded sounds and pictures.





The games described in this chapter may be available on your phone. Check with your service provider for availability.

If you receive an incoming call alert while you are playing **Tetris**[®], **Brick Attack**[™], or **Race 21**[™], the game is paused and exited. You can return to play once the call alert ends. Games do not remain paused if the phone is turned off or loses power.













Tetris

The goal of this game is to guide the falling blocks down the screen to create a solid horizontal row at the bottom. Each time a row is completed, it disappears and the remaining blocks move down one row. The game ends when the new block cannot enter the play field because the area is occupied by another block or obstacle.

1. Select **Menu** → **Fun & Games** → **Tetris**.
2. Press  to select **Yes** at the prompt, “Turn off backlight to conserve battery?”







3. Select an option and press  to select it.
 - **New Game**—Initiates game play. To pause the game, press  or . Pressing  returns you to the menu where you can **Continue Game** to resume or choose from the other available options.
 - **Resume Saved**—Returns you to the game you were last playing.
 - **Scoreboards**—Displays the top five scores for the different game variations, including **No Time Limit** (default), **Timed 2 Min**, **Timed 3 Min**, **Timed 5 Min.**, and **Garbage**.
 - **Settings**—Choose a level of play, sounds, and game type:
 - **Starting level**—Choose a level of play.
 - **Game Type**—Choose type of game.
 - **Sound**—Choose when music will play with this game: **Sound Always**, **During Title**, or **No Sound** (The No Sound setting does not silence the sounds made when you press keys. To silence keys, see “Silencing all sounds” on page 39.)

Navigation: Use the following keys to guide the blocks down the screen:

To:	Use:
Rotate Counterclockwise	
Hard drop	
Move Left	 or  left
Rotate Clockwise	 ,  , or  up
Move Right	 or  right
Soft drop the tile	 or  down
Return to Tetris menu	
Pause	

Brick Attack















The goal of this game is to eliminate bricks arranged in levels. To do this, you send a moving ball upward using a paddle at the bottom of the screen.

1. Select **Menu** → **Fun & Games** → **Brick Attack**.
 2. Press  to select **Yes** at the prompt, “Turn off backlight to conserve battery?”
 3. Press  to select **New**.
 - To pause the game, press , then press  to **Resume**.
 - To move the paddle, press  left or right.
- To exit the game, highlight **Exit** and press .

Race 21

This game is a timed variation of Blackjack. Each game comprises three 90-second rounds. To score points, add cards in each of the four columns, trying to reach but not exceed 21 in each column within during the course of the game.

To play:

1. Select **Menu** → **Fun & Games** → **Race 21**.
 2. Press  to select **Yes** at the prompt, “Turn off backlight to conserve battery?”
 3. Select **New Game**. The first card to be placed is shown at the top left of the screen. Press a key to add a card to the row as follows:
 -  Add cards to the first row
 -  Add cards to the second row
 -  Add cards to the third row
 -  Add cards to the fourth row
- Shortcut:** Press  left or right to choose arrows at the bottom of the screen. Then press  to add cards to corresponding rows.
- Note:** Each time you place a card, it is replaced with a new one.
4. Continue placing cards until you are satisfied with your selections.
 - To pause the game, press .
 - To end the game and return to the home screen, press .
 - You lose points each time you exceed 21 in a column.
 - Remember, there is a time limit!
 - Select **Skip** to skip one card per round.
 5. Press  to select  to get your score and advance to the next round.
 6. Select an option and press  to select it.
 - **New Game**—Initiates game play. To pause the game, press . From here you can choose **Resume**, **New** or **Quit**.
 - **Resume Game**—Returns you to the game you were last playing.
 - **Scoreboard**—Provides you with the top five scores.
 - **Sounds**—Choose when you hear music with this game. Select from **Sound Always**, **During Title**, or **No Sound**.
 7. Press  to end all games.

Doodler

Doodler™ allows you to create and manipulate images, import shapes, and save images as screen savers.

1. Select **Menu** → **Fun & Games** → **Doodler**.
2. Press **OK** to select **Yes** at the prompt, “Turn off backlight to conserve battery?”
3. Wait 5 seconds for the intro screen to disappear, or press **OK** to clear it.
4. Select **New Doodle** to open the drawing screen. You will see a flashing cursor in the middle of the screen:

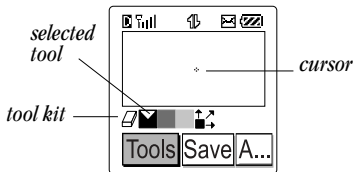

By default, the selected tool is “draw black” (selected colors are indicated by a white triangle). This means that when you move the cursor, it will draw a black line.

5. Use keys 1-9 to move the cursor around the screen.



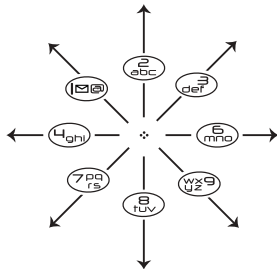

The following diagram shows the direction each key will take the cursor.



Note: Pressing the 5 key brings the cursor back to center.

Using the Tool Kit



- To change between the tools in the toolkit, highlight **Tools** and press **OK** repeatedly to cycle through the options.

-  eraser
-  draw black
-  draw dark gray
-  draw light gray
-  move cursor

Tip: For a shortcut to the Move feature, press .

Modifying the Doodle

There are several options at the bottom of the drawing screen which allow you to modify your doodle. Press  right or left to highlight an option:

- **Add Shape** allows you to select an existing shape such as a heart, a circle, or a square, and re-size, rotate, or move it. Select **Done** when finished.
- **Size** lets you enlarge or shrink a predefined shape by pressing  repeatedly. There are three size options.
- **Rotate** allows you to change the position in 90-degree increments.
- **Move** enables you to move the image around the screen using keys 1-9.
- **Clear** allows you clear the entire screen.
(*Tip:* The shortcut to this feature is .)

Saving the Doodle

It is a good idea to save the doodle while you are working on it. If you receive a call while creating an unsaved doodle, it will be lost.

- Highlight **Save** and press . The image will be saved in the **My Pictures** folder. (See page 67.)

Note: If you make changes to an existing doodle, you must save it with a different name.



Resuming Doodles

- To return to the last saved doodle you were working on, select **Menu** → **Fun & Games** → **Doodler** → **Resume Doodle**.
- To return to another saved doodle, select **Menu** → **Fun & Games** → **Doodler** → **My Pictures**.

My Sounds

Your Kyocera 3245 allows you to store sounds downloaded over the air and use them as ringers. (Check with your service provider for availability of over-the-air downloading.)

To access stored sounds:

1. Select **Menu** → **Fun & Games** → **My Sounds**.
2. Press  up or down to scroll through the sounds.
3. Highlight an option and press  to select it:

- **Play** allows you to listen to the sound.
- **Assign** allows you to use the sound as a ringer on your phone.
- **Delete** erases the sound from your My Sounds list.

- **Exit** returns you to the home screen.



Note: When you run out of memory and want to add additional graphics, you will need to delete older files.

My Pictures

The My Pictures menu stores graphics you have created using the Doodler or received via text messaging.

Note: All graphics downloaded over the air are also stored in the Screen Saver menu.

To view, edit, or erase graphics:

1. Select **Menu** → **Fun & Games** → **My Pictures**.
2. Press  up or down to scroll through the graphics.
3. Highlight an option and press  to select it:
 - **Assign** sets your graphic as a screen saver.
 - **Delete** erases the graphic from memory. The graphic is also erased from the Screen Saver menu. (This option is available only with graphics you have created or saved. You cannot delete predefined graphics.)

Customer support

Your service provider's customer support department may be accessible directly from your phone when you dial a number such as *611 (check with your service provider). They can answer questions about your phone, phone bill, call coverage area, and specific features available to you, such as call forwarding or voicemail.

For questions about the phone features, refer to the materials provided with your phone, or visit **www.kyocera-wireless.com**.

For additional questions, you may contact the Kyocera Wireless Corp. Customer Care Center in any of the following ways:

- Web site: **www.kyocera-wireless.com**
- Email: phone-help@kyocera-wireless.com

Before requesting support, please try to reproduce and isolate the problem. When you contact the Customer Care Center, be ready to provide the following information:

- The name of your service provider.

- The actual error message or problem you are experiencing.
- The steps you took to reproduce the problem.
- The phone's electronic serial number (ESN).
To find the ESN:

- a. Remove the battery.
- b. Locate the white label on the back of the phone. Your phone's 11-digit ESN begins with "D" and is located on the label.

Phone accessories

To shop for phone accessories, visit **www.kyocera-wireless.com/store**, or call (800) 349-4188 (U.S.A. only) or (858) 882-1410.

Become a product evaluator

To participate in the testing and evaluation of Kyocera Wireless Corp. products, including cellular or PCS phones, visit **beta.kyocera-wireless.com**.

INDEX

Numerics

1-Touch dialing, 14

A

accounts (setting), 46

Alarm Clock, 8, 59

alerts

browser, 56

for headsets, 46

for messages, 46

for missed calls, 12

all calls timer, 16

Auto-Answer, 52

Auto-Erase setting, 35

auto-hyphenation, 44

AutoText, 30, 31, 36

B

backlighting, 43

banner, 42

battery, 1

drain, 2

removing, 2

safety guidelines, 2

bookmarks, 55

Brick Attack, 63

browser prompt, 56

browser timer, 56

C

Calculator, 60

callback number, 30

calls

making/answering, 3, 10

missed, 12

timing, 16

Com Port speed, 47

contacts

calling, 10, 27

classifying, 24, 26

editing, 25

erasing, 25

finding, 27

storing, 24

Contacts directory, 24

contrast, 44

countdown timer, 61

D

data/fax setup, 16, 47

delivery receipt

for text messages, 30

digital mode, 7

display contrast, 44

Doodler, 65

E

emergency

emergency services, 17

position location, 8, 48

emoticons, 30

erasing

all contacts, 45

text messages, 34

external devices

hands-free car kit, 11

laptop or PC, 47

TTY/TDD, 47

F

Fast Find, 27

fax mode, 47

finding a saved phone number, 27

flashing lights, 44

frequent contacts, 27

G

games

Brick Attack, 63

Doodler, 65

Race 21, 64

Tetris, 62

group lists

creating, 35

using, 29

H

hands-free car kit
answer using voice, 11, 52
purchasing, 68

hands-free headset
and phone ringer, 46
button, 19
jack, 4
purchasing, 68

hard pause, 25

holding calls, 11

I

icons, 7

InBox, 33

K

keyguard, 16
icon, 8
setting, 15

keypad, locking, 15

L

language, 44

lights
backlighting, 43
lights-only mode, 8, 39
photosensitivity, 44

limiting calls out, 45

lock code, 45

locking
keypad, 15
phone, 45

M

memory (saving), 34

menu view, 43

messages
see voicemail *or* text messages

minutes
counting, 16

minutes (counting), 16

missed calls, 12

N

net alerts, 56

normal text mode, 20

number mode, 20

number type, 24

O

OutBox, 31

P

pauses in phone numbers, 25

phone book (Contacts directory),
24

phone lines
multiple, 46
setting, 46

phone numbers

editing, 26

finding quickly, 27

saving, 24

types of, 24

verifying your own, 3

phone, unlocking, 45

position location
for finding phone, 48

indicators, 8

settings, 48

power backlighting, 43

power save mode, 10

prepend, 13, 26

priority of messages, 30

R

Race 21, 64

recent calls timer, 16

redialing a number, 10

resetting the phone, v

ringers
choosing types, 40
for different calls, 40
roaming, 19
silencing, 3
volume, 40

roaming, 7

alerts, 18

controlling, 18

rejecting calls, 18

ringer, 19

S

- saved phone numbers
 - editing, 26
 - searching for, 27
- Scheduler, 58
- screen contrast, 44
- screen savers, 42
- secret contacts, 13, 24
- security, 45
- shortcuts
 - accessing, 41
 - creating, 41
- silencing all sounds, 39
- silent mode
 - icons, 8
 - setting, 39
- sounds, 66
- speakerphone, 12
 - volume, 40
- speed dialing, 14
- sport clip, 9
- Starting, 54
- Stopwatch, 61
- symbol mode, 22

T

- technical support, 68
- Tetris, 62
- text entry
 - changing text modes, 22
 - eZiText mode, 20

- normal text mode, 20
- number mode, 20
- special characters, 21
- symbol mode, 20
- text messages
 - callback number, 30
 - erasing, 34
 - pre-written (AutoText), 30, 31, 36
 - retrieving, 33
 - Direct View, 33, 37
 - saving to outbox, 32
 - sending new, 29
 - sending saved, 31
 - to multiple recipients, 35
- time format, 42
- time pause, 25
- Timer, 61
- timers
 - all calls, 16
 - browser, 56
 - recent calls, 16
- Tip Calculator, 60
- TTY/TDD, 47

U

- unlocking the phone, 45

V

- vibrate, 39
 - icon, 8

- lights only, 39
- voice dialing
 - digit dialing, 51
 - expert mode, 51
 - voice tags
 - add to contact, 24, 50
 - editing, 50
 - voice training, 53
 - voice wake-up, 52
- voice memo
 - erasing, 57
 - naming, 57
 - playing, 57
- voicemail
 - accessing, 15
 - setting up, 3, 14
- volume
 - earpiece, 15, 40
 - key beep, 41
 - ringer, 40
 - speakerphone, 40

W

- Web
 - alerts, 56
 - security, 54
- Web Browser, 54
 - bookmarking a site, 55
 - prompt, 56
 - searching for a site, 55
 - timer, 56



82-K5348-3EN, Rev. 001

KYOCERA WIRELESS CORP.
10300 CAMPUS POINT DRIVE
SAN DIEGO, CALIFORNIA 92121 USA
www.kyocera-wireless.com