

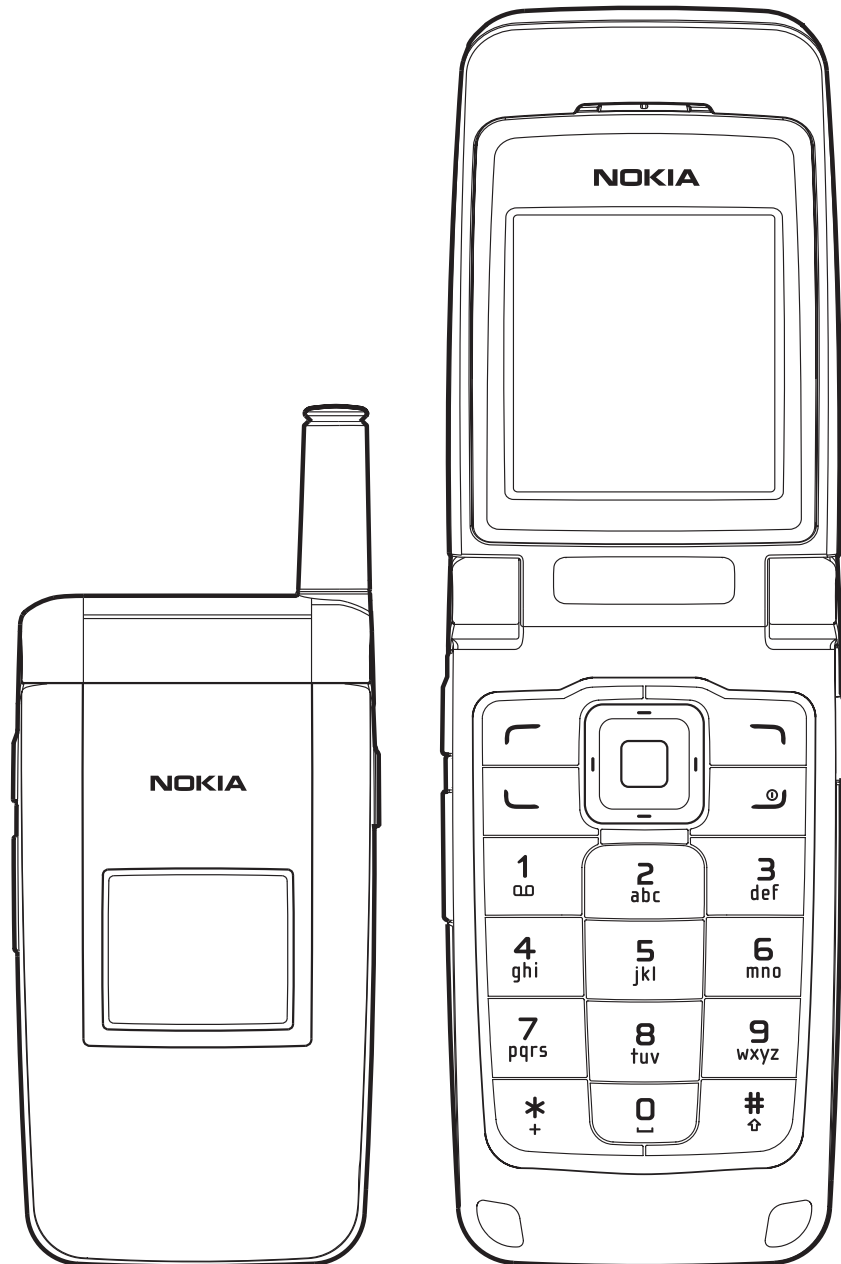

User Guide Guide d'utilisation

Nokia 2855i User Guide



Remarque: La version française du guide se trouve à la page 91

Part No. 9244897, Issue No. 1

Copyright ©2006 Nokia. All rights reserved.

Nokia, Nokia Connecting People, Nokia 2855i, Pop-Port, and the Nokia Original Enhancements logos are trademarks or registered trademarks of Nokia Corporation. Other company and product names mentioned herein may be trademarks or trade names of their respective owners.

US Patent No 5818437 and other pending patents. T9 text input software Copyright ©1999-2006. Tegic Communications, Inc. All rights reserved.



Bluetooth wireless technology is a registered trademark of Bluetooth SIG, Inc.



Includes RSA BSAFE cryptographic or security protocol software from RSA Security.



Java is a trademark of Sun Microsystems, Inc.

The information contained in this user guide was written for the Nokia 2855i product. Nokia operates a policy of ongoing development. Nokia reserves the right to make changes to any of the products described in this document without prior notice.

UNDER NO CIRCUMSTANCES SHALL NOKIA BE RESPONSIBLE FOR ANY LOSS OF DATA OR INCOME OR ANY SPECIAL, INCIDENTAL, AND CONSEQUENTIAL OR INDIRECT DAMAGES HOWSOEVER CAUSED. THE CONTENTS OF THIS DOCUMENT ARE PROVIDED "AS IS." EXCEPT AS REQUIRED BY APPLICABLE LAW, NO WARRANTIES OF ANY KIND, EITHER EXPRESS OR IMPLIED, INCLUDING, BUT NOT LIMITED TO, THE IMPLIED WARRANTIES OF MERCHANTABILITY AND FITNESS FOR A PARTICULAR PURPOSE, ARE MADE IN RELATION TO THE ACCURACY AND RELIABILITY OR CONTENTS OF THIS DOCUMENT. NOKIA RESERVES THE RIGHT TO REVISE THIS DOCUMENT OR WITHDRAW IT AT ANY TIME WITHOUT PRIOR NOTICE.

Copyright protections may prevent some images, music (including ringing tones), and the content from being copied, modified, transferred, or forwarded.

EXPORT CONTROLS

This device may contain commodities, technology, or software subject to export laws and regulations from the U.S. and other countries. Diversion contrary to law is prohibited.

FCC/INDUSTRY CANADA NOTICE

Your device may cause TV or radio interference (for example, when using a telephone in close proximity to receiving equipment). The FCC or Industry Canada can require you to stop using your telephone if such interference cannot be eliminated. If you require assistance, contact your local service facility. This device complies with part 15 of the FCC rules. Operation is subject to the following two conditions: (1) This device may not cause harmful interference, and (2) this device must accept any interference received, including interference that may cause undesired operation. Any changes or modifications not expressly approved by Nokia could void the user's authority to operate this equipment.

Contents

For your safety.....	4
Welcome.....	7
1. Phone at a glance.....	8
2. Set up your phone.....	13
3. Text entry.....	19
4. Log.....	22
5. Messaging.....	24
6. Contacts.....	32
7. Gallery.....	40
8. Media.....	41
9. Settings.....	42
10. Organizer.....	63
11. PC connectivity.....	74
12. Enhancements.....	75
13. Reference information.....	77
Care and maintenance.....	80
Additional safety information.....	81
Index.....	87

For your safety

Read these simple guidelines. Not following them may be dangerous or illegal. Read the complete user guide for further information.



SWITCH ON SAFELY

Do not switch the phone on when wireless phone use is prohibited or when it may cause interference or danger.



ROAD SAFETY COMES FIRST

Obey all local laws. Always keep your hands free to operate the vehicle while driving. Your first consideration while driving should be road safety.



INTERFERENCE

All wireless phones may be susceptible to interference, which could affect performance.



SWITCH OFF IN HOSPITALS

Follow any restrictions. Switch the phone off near medical equipment.



SWITCH OFF IN AIRCRAFT

Follow any restrictions. Wireless devices can cause interference in aircraft.



SWITCH OFF WHEN REFUELING

Do not use the phone at a refueling point. Do not use near fuel or chemicals.



SWITCH OFF NEAR BLASTING

Follow any restrictions. Do not use the phone where blasting is in progress.



USE SENSIBLY

Use only in the normal position as explained in the product documentation. Do not touch the antenna unnecessarily.



PLAY SAFELY

Use of vibration can aggravate injuries. Do not turn vibration on if you have any ailment in the bones or joints of your fingers, hands, wrists, or arms.



QUALIFIED SERVICE

Only qualified personnel may install or repair this product.



ENHANCEMENTS AND BATTERIES

Use only approved enhancements and batteries. Do not connect incompatible products.



WATER-RESISTANCE

Your phone is not water-resistant. Keep it dry.



BACKUP COPIES

Remember to make back-up copies or keep a written record of all important information stored in your phone.



CONNECTING TO OTHER DEVICES

When connecting to any other device, read its user guide for detailed safety instructions. Do not connect incompatible products.



EMERGENCY CALLS

Ensure the phone is switched on and in service. Press the end key as many times as needed to clear the display and return to the start screen. Enter the emergency number, then press the call key. Give your location. Do not end the call until given permission to do so.

■ About your device

The wireless device described in this guide is approved for use on the CDMA 800, and 1900, and AMPS networks, and also receives signals from the global positioning system. Contact your service provider for more information about networks.

When using the features in this device, obey all laws and respect privacy and legitimate rights of others.

When taking and using images or video clips, obey all laws and respect local customs as well as privacy and legitimate rights of others.



Warning: To use any features in this device, other than the alarm clock, the device must be switched on. Do not switch the device on when wireless device use may cause interference or danger.

■ Network services

To use the phone you must have service from a wireless service provider. Many of the features in this device depend on features in the wireless network to function. These network services may not be available on all networks or you may have to make specific arrangements with your service provider before you can utilize network services. Your service provider may need to give you additional instructions for their use and explain what charges will apply. Some networks may have limitations that affect how you can use network services. For instance, some networks may not support all language-dependent characters and services.

Your service provider may have requested that certain features be disabled or not activated in your device. If so, they will not appear on your device menu. Your device may also have been specially configured. This configuration may include changes in menu names, menu order and icons. Contact your service provider for more information.

This device supports WAP 2.0 protocols (HTTP and SSL) that run on TCP/IP protocols. Some features of this device, such as *Mobile web* require network support for these technologies.

■ Shared memory

The following features in this device may share memory: *Messaging*, *Contacts*, *Gallery*, *Organizer*, and *Applications*. Use of one or more of these features may reduce the memory available for the remaining features sharing memory. For example, saving many photos to the *Gallery* may use all of the available memory. Your device may display a message that the memory is full when you try to use a shared memory feature. In this case, delete some of the information or entries stored in the shared memory features before continuing. Some of the features, such as *Messaging* and *Contacts*, may have a certain amount of memory specially allotted to them in addition to the memory shared with other features.

Welcome

Congratulations on your purchase of this Nokia mobile phone. Your phone provides many functions which are practical for daily use, such as a hands-free loudspeaker, and more. Your phone can also connect to a PC, laptop, or other device using a USB data cable or Bluetooth wireless technology.

■ Register your phone

Make sure to register your phone at www.warranty.nokiausa.com or call 1-888-NOKIA-2U (1-888-665-4228) so that we can serve your needs better if you should call a customer center or to have your phone repaired.

■ Getting help

Find your phone label

If you need help, the Nokia Care Contact Center is available for assistance. Before calling, we recommend that you write down the electronic serial number (ESN) or the mobile equipment ID (MEID) of your phone and have it available.

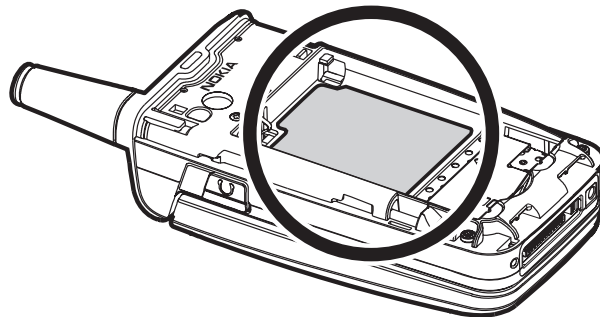

The ESN or MEID is found on the type label, which is located beneath the battery on the back of the phone. See "Remove the back cover," p. 14 and "Remove the battery," p. 14 for more information.

Additional information

Check www.nokia.com/support or your local Nokia Web site for the latest version of this guide, additional information, downloads, and service related to your Nokia product.

Accessibility solutions

Nokia is committed to making mobile phones easy to use for all individuals, including those with disabilities. For more information visit the Web site at www.nokiaaccessibility.com.

1. Phone at a glance

■ Keys and parts

- Earpiece (1)
- Main display (2)
- Left selection key (3)
- Call key (4)
- Keypad (5)
- Selection and scroll key (6)
- Center selection key (7)
- Right selection key (8)
- End and power key (9)
- Charger port (10)
- Pop-Port connector (11)
- Microphone (12)

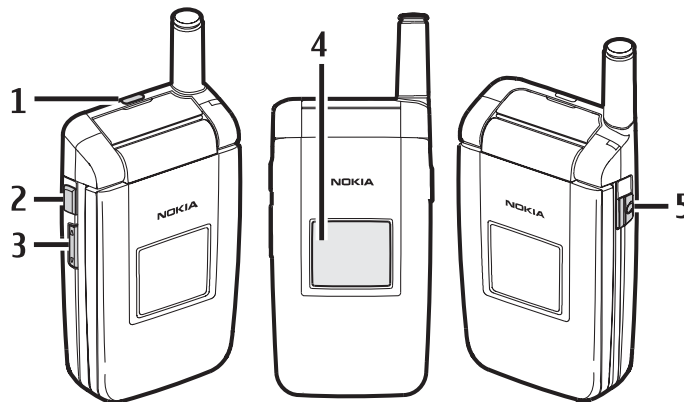
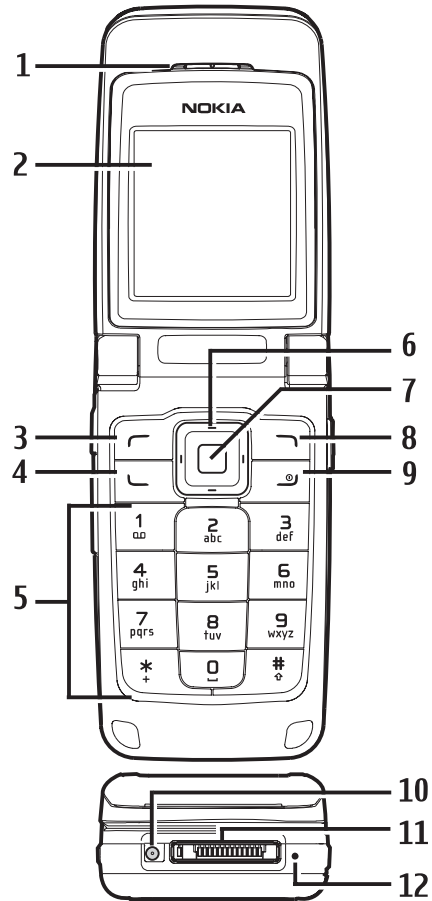

- Loudspeaker (1)
- Answer any or Loudspeaker key (2)
- Volume control key (3)
- Mini display (4)
- 2.5 mm Headset connector (5)

■ Standby mode

Depending on your wireless service provider and the model number of your phone, some or all of the following selection keys may appear in the standby mode.

The standby mode is home base and indicates your phone is idle.

Signal strength (1)—More bars indicate a stronger network signal.

Menu (2)—Press the center selection key to select this option.

Go to (3)—Press the left selection key to select this option.

Names or network operator menu (4)—Press the right selection key to select this option.

Battery level (5)—A filled-in battery icon indicates a fully charged battery.

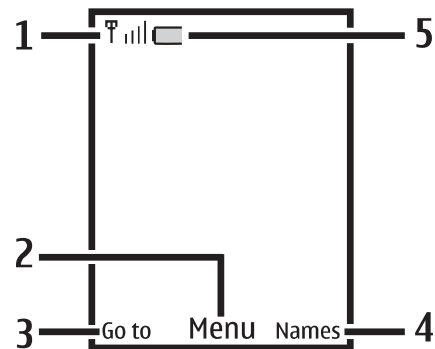

■ Quick keys

Depending on your wireless service provider and the model number of your phone, some or all of the following scroll key shortcuts may be available in the standby mode.

In the standby mode, the four-way scroll and center selection keys instantly take you to frequently-accessed menus:

Scroll up key—Connect with the minibrowser.

Scroll right key—Go to downloads.

Scroll down key—Go to the Bluetooth menu.

Scroll left key—Create a text message.

Center selection key—Selects menus and submenus to which you have scrolled.

Answer any or Loudspeaker key—Press to answer a call with the fold closed. Press and hold during a call to switch to the loudspeaker.

■ Indicators and icons

Depending on your wireless service provider and the model number of your phone, some or all of the following indicators and icons may appear in the standby mode.



You have one or more text or picture messages. See "Read and reply to text messages," p. 25.



Your phone keypad is locked. See "Keyguard," p. 18



You have one or more voice messages. See "Voice messages," p. 30.

Phone at a glance



Your phone is set to the silent profile. See "Profiles," p. 42.



The alarm clock is on. See "Alarm clock," p. 63.



The countdown timer is running. See "Timers," p. 71



The stopwatch timing is running in the background.
See "Stopwatch," p. 72.



Integrated hands free or loudspeaker is active.



The timed profile is selected. See "Profiles," p. 42.



Hearing aid mode is active.



Bluetooth connectivity is enabled.



or  Location sharing is set to on or to emergency only.



 ,  ,  , or  An enhancement is connected to the phone.



Phone is roaming outside of your home network



Phone is in a digital network. See "Network services," p. 6.



Phone is in an analog network. See "Network services," p. 6



Phone is in a 1XRTT network. See "Network services," p. 6.

Phone menus

Phone features are grouped according to function and are accessed through the main menus. Each main menu contains submenus and lists from which you can select or view items and customize your phone features. You can access these menus and submenus by using the scroll method or by using a shortcut.



Note: Some features may not be available, depending on your network.
For more information, contact your wireless provider.

Scroll method

1. In the standby mode, to select *Menu* use the center selection key. To scroll through the main menu, use the scroll key.

On the right side of the screen, a scroll bar is displayed with a tab that moves up or down as you move through the menus. This provides a visual representation of your current position in the menu structure.



- When you arrive at a menu, select *Select* (the center selection key) to enter submenus.

Select *Back* from the submenu level to return to the previous menu.

Press the end key to return to the standby mode from any menu or submenu.

Main menu display

You can control whether your phone main menu is displayed as a *List*, or *Grid*. By default, the main menu displays in *Grid* format.

In the standby mode, select *Menu > Options > Main menu view > List or Grid*.

In-phone help

Many features have brief descriptions (help text) that can be viewed on the display. To view these descriptions, scroll to a feature, and wait for about 15 seconds. Scroll down to view all of the description, or select *Back* to exit.

In order to view the descriptions, you must activate help text. See "Help text activation," p. 54.

■ Security feature

The security feature protects your device from unauthorized outgoing calls or denies access to stored information with a lock code. The lock code is a four-digit number, while the security code is a five-digit number. By default, the security feature uses the lock code (defaulted to the last four digits of your phone number) instead of the security code to protect your phone.

To access the *Security* menu, do the following:

- In the standby mode, select *Menu > Settings > Other settings > Security*.
- Enter the lock code, and select *OK*. See "Security," p. 58 for more information.



Note: The security and lock codes are set by default to the last four digits of your phone number. If this does not work, contact your wireless service provider for more help.

To restore the factory settings, do the following:

- In the standby mode, select *Menu > Settings > Other settings > Restore settings*.
- Enter the lock code, and select *OK*.



Note: Depending on your wireless service provider, your phone may ask for the security code (default setting of 12345 or 00000) instead of the lock code.

■ Go to functions

The *Go to* menu allows you to change the function of the left selection key on your phone so that your most frequently used functions can be quickly accessed from the *Go to* menu in the standby mode.

Select options

1. In the standby mode, select *Go to > Options > Select options*.
2. Scroll to the options you want to add.
3. Select *Mark* to add an option or *Unmark* to remove an option.
4. Select *Done* when you have added all desired options.
5. Select *Yes* to save the changes.
6. In the standby mode, select *Go to* to display a list of the options that you selected in step 3.

Organize functions

In the standby mode, select *Go to > Options > Organize*. Scroll to an option, select *Move*. Scroll to move the option to a new location, and select *OK*. You can repeat the procedure to customize your *Go to* menu.

Select *Done > Yes* to save the changes.

2. Set up your phone

■ Antenna

Your device has an internal antenna and an external antenna that works when fully extended.

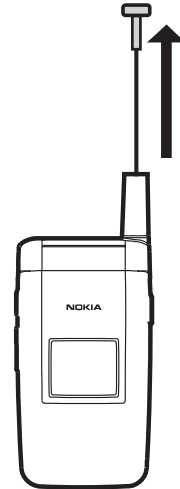

Hold the device as you would any other telephone with the antenna area pointed up and over your shoulder.

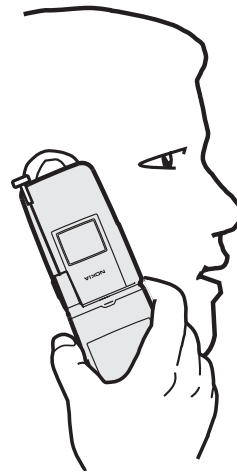

Note: As with any other radio transmitting device, do not touch the antenna unnecessarily when the device is switched on. Contact with the antenna affects call quality and may cause the device to operate at a higher power level than otherwise needed. Avoiding contact with the antenna area when operating the device optimizes the antenna performance and the battery life.

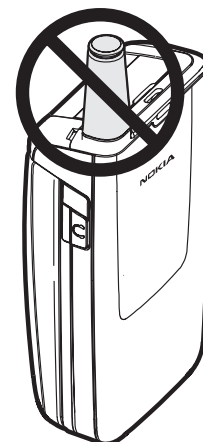

■ Battery

Always switch off the power and disconnect the charger before removing the battery. Avoid touching electronic components while changing the covers. Always store and use the device with the covers attached.

Prolonged, continuous use of your device may increase the device temperature. The increased temperature is a normal function of this product and does not pose a safety concern for you or the device. If the temperature is uncomfortable to you, use a headset or allow your device to return to room temperature before your next call.

Remove the back cover

1. With the back of the phone facing you, press down and hold the back cover latch.
2. Slide the back cover toward the bottom of the phone, lift up and remove.

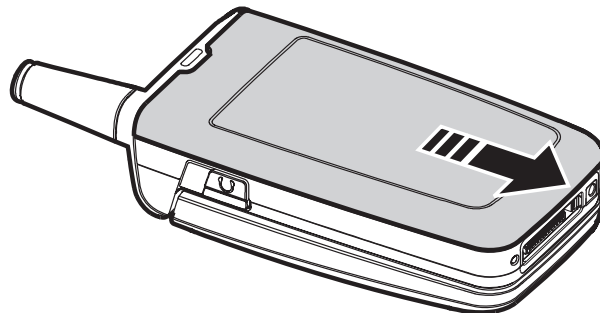

Remove the battery

After you have removed the back cover, insert your finger into the finger grip, and lift the battery from its compartment.

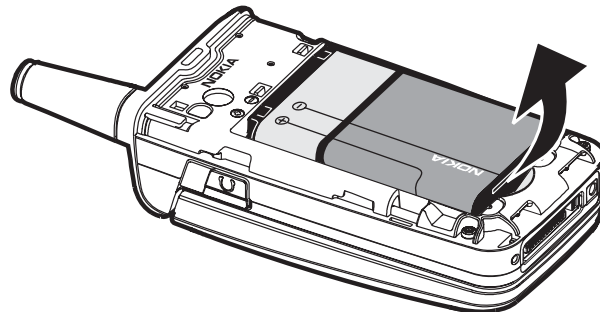

UIM (CDMA SIM) card slot

Your phone has a built-in UIM card slot. However, the UIM is not functional in this phone model. Avoid placing anything into the UIM card slot.

Replace the battery

1. Insert the battery, gold-colored contact end first, into the battery slot.
2. Push down on the other end of the battery to snap the battery into place.

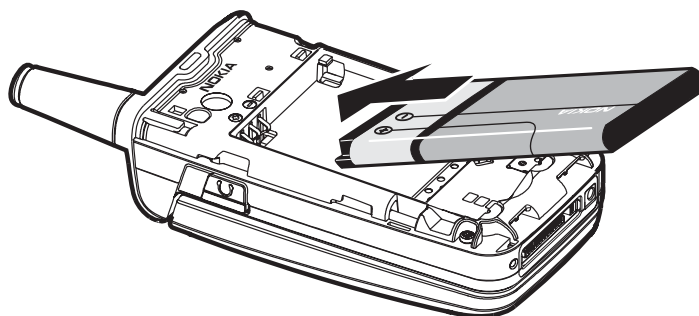

Replace the back cover

1. Set the back cover on the phone with the cover tabs aligned with the slots in the phone.
2. Press the back cover latch down, and slide the back cover toward the top of phone.
3. Make sure back cover latch is secure.

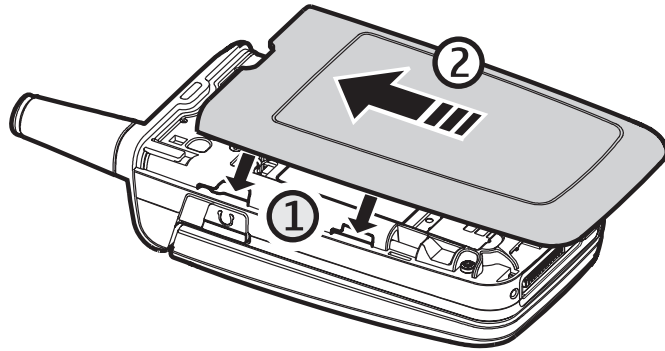

Charge the battery

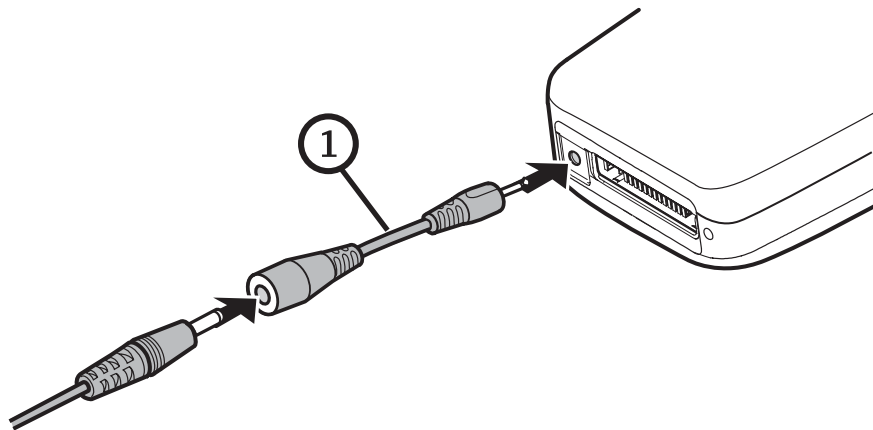

1. Plug the charger transformer into a standard ac outlet.
2. Insert the charger output plug into the round jack at the bottom of the phone. If necessary, you can use a Nokia CA-44 adapter cable (1) to connect a charger and the phone.

After a few seconds, the battery indicator in the display scrolls. If the battery is completely discharged, it may take a few minutes before the charging indicator appears on the display or before any calls can be made.

■ Turn your phone on or off

1. To turn your phone on or off, press and hold the end key for at least 3 seconds.
2. Enter the lock code, if necessary, and select *OK*.

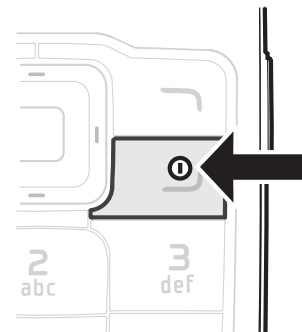

■ Connect the headset

A compatible headset such as the Nokia HS-5 may be purchased with your phone or separately as an enhancement. See "Enhancement settings," p. 56 for information.

1. Plug the headset connector into the Pop-Port™ connector at the bottom of your phone.

 appears on the display.

2. Position the headset on your ear.
- With the headset connected, you can make, answer, and end calls as usual.

- Use the keypad to enter numbers.
- Press the call key to place a call.
- Press the end key to end a call.

You can also plug a compatible headset, such as the such as the Nokia HS-9 Universal Headset, into the 2.5-mm headset jack on the side of your phone to allow hands-free operation. See "Enhancement settings," p. 56.



Warning: When you use the headset, your ability to hear outside sounds may be affected. Do not use the headset where it can endanger your safety.

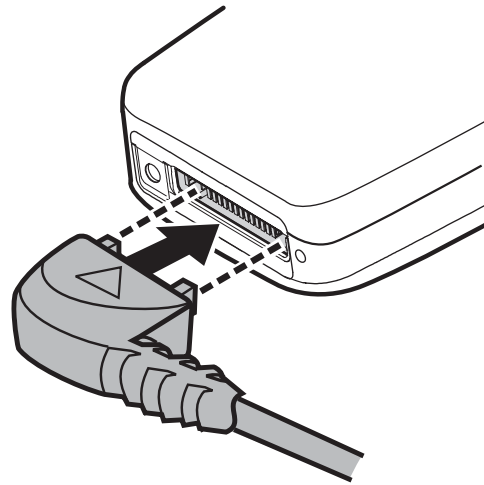

■ Make calls

Using the keypad

1. Enter the phone number (including the area code), and press the call key.
To delete a character to the left of the cursor, select *Clear*.
2. To end the call, press the end key. To cancel the call attempt, select *End call*.

Use the save contact option

1. In the standby mode, enter the phone number (including the area code) and select *Save*, enter a name for the contact, and select *OK*.
2. To make the call, press the call key. To return to the standby mode, select *Done*.

Use the contacts list

1. In the standby mode, scroll down to display your contacts.
2. Scroll to the contact you wish to dial, and press the call key. To view details of the entry, select *Details*.

Use the last dialed number

1. In the standby mode, press the call key to display the last 30 numbers dialed.
2. Scroll to the number or name you wish to redial, and press the call key.

Make a conference call

Conference calling is a network service that allows you to take part in a conference call with two other participants.

1. Make a call to the first participant.
2. With the first participant on the line, select *Options > Add new call*.
3. Enter the phone number of the second participant; or, to retrieve a number from your contacts, select *Search* and the number you want to call.
4. Press the call key. The first participant is put on hold.
5. When the second participant picks up, press the call key to connect the calls.
6. To end the conference call, select *Options > End all calls*, or press the end key.

■ Answer calls

Answer or silence an incoming call

1. To answer the call, press the call key or select *Answer*.
2. To reject the call, press the end key. The ringer is muted, and the call is immediately forwarded to voice mail.

Select *Silence* to mute the ringing tone. Select *Dismiss* or do nothing, and the call is eventually forwarded to voice mail.

If your phone is set to *Silent* in the *Profiles* menu, select *Dismiss*, and the call is forwarded to voice mail.

Adjust the earpiece volume

Press the up arrow or down arrow on the volume key located on the right side of your phone to adjust the volume of the earpiece. When adjusting the volume, a bar chart appears in the display indicating the volume level.

Answer a call with the keypad locked

To answer a call with the keypad locked, simply press the call key.

During the call, all features function as normal. When you end or reject the call, the keypad automatically relocks. See "Keyguard," p. 18 for details.

When the device is locked, calls may be possible to the official emergency number programmed into your device.

Use the loudspeaker



Warning: Do not hold the device near your ear when the loudspeaker is in use because the volume may be extremely loud.

You can use your phone loudspeaker during a call:

- To activate the loudspeaker, select *Loudsp.*
- To deactivate the loudspeaker, select *Normal.*

The loudspeaker is deactivated automatically when a call or a call attempt ends or when certain enhancements are connected.

Mute phone during call

To mute your phone during a call, select *Mute*; to unmute the phone, select *Unmute*.

Options during a call

Many of the options that you can use during a call, are network services. Check with your wireless service provider for more information.

During a call, select *Options* and one of the following:

Loudspeaker or Normal—Activate or deactivate the loudspeaker while in a call.

Add new call—Initiate a conference call. See "Make a conference call," p. 17 for information.

Save—Save a number entered during a call.

Add to contact—Add a number entered during a call to a contact in your list.

End all calls—Disconnect from all active calls.

Send touch tones—Enter the numbers, and select *Tones* to send the numbers as tones.

Contacts—View the contacts list.

Menu—View the phone menu.

■ Keyguard

With keyguard, you can lock the keypad to prevent keys from being pressed accidentally. Remember to lock your phone keypad to prevent accidental calls or activation of features. If the keypad is locked, it unlocks when you receive a call. After the call, the lock automatically reactivates.

When the keyguard is on, calls may be possible to the official emergency number programmed into your device.

If the phone is closed, open it. When the phone is open:

- To unlock the keypad, select *Unlock*, and press * within 2 seconds.
- To lock the keypad, select *Menu*, and press * within 2 seconds.

3. Text entry

You can use two methods for entering text and numbers: standard mode and predictive text mode.

■ Standard mode

Standard mode is the only way to enter text into the contacts list, and to rename caller groups.

Text (Abc)

- Press a key once to insert the first letter on the key, twice for the second letter, etc. If you pause briefly, the last letter in the display is accepted and your phone awaits the next entry.
- Press 0 to enter a space, thereby accepting a completed word.
- Press 1 as many times as necessary to scroll through a list of commonly used characters.
- Press * to display a complete list of special characters.
- Press and hold # to open *Editor settings*, and select *Number mode*, *Prediction on* or *Prediction off*, or *Writing language*.

Numbers (123)

To switch to 123 mode from Abc mode, press and hold # at any message entry screen to open the *Editor settings*. Select *Number mode*, and the device returns to the message entry screen and switches the ABC icon in the upper area of the display to the 123 icon (or back). To return to Abc mode, press and hold #.

Change language

To change the language, do the following:

1. Press and hold # to open the *Editor settings* menu list.
2. Select *Writing language*, and the new language.

The phone will return to the message entry screen, and you can compose in the new language.

Punctuation and special characters

While at any text entry screen, press * to display special characters (press and hold * if predictive text is on). Press * again to cycle through all available characters. Scroll to navigate through the list of special characters. Once you have scrolled to a character, select *Insert* to insert the character into your message.

■ Predictive text mode

Predictive text input allows you to write messages quickly using your keypad and the built-in dictionary. It is much faster than the standard mode method, because for each letter, you only press the corresponding key on your keypad once.

Activate and deactivate

At any text entry screen, select and hold *Options* to turn predictive text on or off depending on previous mode, or select *Options > Prediction on or Prediction off*. Press # twice to change from predictive text mode to standard mode and back.

Enter text

The illustration below simulates your display each time a key is pressed. For example, to write Nokia with predictive text on and with the English dictionary selected, press each of the following keys once:

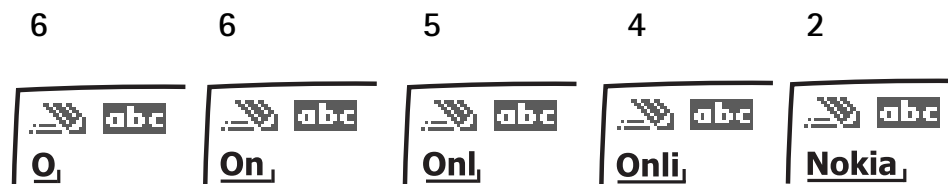

- Press 0 to enter a space and begin writing the next word.
- If a displayed word is not correct, press * to see other matches. To return to the previous word in the list of matches, select *Prev*.
- If ? appears after a word, it is not in the dictionary. Select *Spell* to add the word to the dictionary.
- Press 1 to insert a period into your message.
- Press and hold * to display special characters. Press * again to cycle through all available characters.
- Press and hold the specific number key to enter a number.
- Press and hold # to open *Editor settings*, and select *Number mode*, *Prediction on or Prediction off*, and *Writing language*.

■ Change case and mode

Press # to switch between uppercase, lowercase, and sentence case, as well as standard and predictive text modes. Case and mode are indicated by the following icons that appear in the upper left of the display screen.



Uppercase text: standard mode is on.



Lowercase text: standard mode is on.



Sentence case text: standard mode is on. Only available at the beginning of a sentence.



Uppercase text: predictive text is on.



Lowercase text: predictive text is on.



Sentence case text: predictive text is on. Only available at the beginning of a sentence.

■ Delete text

To delete text, use one of the following options:

- Select *Clear* to backspace the cursor and delete a character.
- Select and hold *Clear* to backspace continuously and delete characters.

4. Log



Log stores information about the last 30 missed, 30 received, or 30 dialed calls. It also adds the total duration of all calls. When the number of calls exceeds the maximum, the most recent call replaces the oldest.

Whether viewing missed, received, or dialed calls, the menu options are the same:

Time of call—Display the date and time of the call.

Send message—Send a message to the number.

Use number—Edit the number and associate a name with the number.

Save—Enter a name for the number and save it to your contacts list.

Add to contact—Add the number to an existing name in your contacts list, if the number is not associated with a name.

Delete—Clear the number from memory.

Call—Call the number.

■ View missed calls

Missed calls are calls that were never answered. The missed calls feature does not function when your phone is switched off.

1. In the standby mode, select *Menu > Log > Missed calls*; if a missed call notification appears, select *List*.
2. Scroll to a name or number, select *Options* and a menu option.

■ View received calls

Received calls are calls that have been answered.

1. In the standby mode, select *Menu > Log > Received calls*.
2. Scroll to a name or number, select *Options* and a menu option.

■ View dialed numbers

Dialed calls are numbers you have previously dialed from your phone:

1. In the standby mode, press the call key; or select *Menu > Log > Dialed numbers*.
2. Scroll to a name or number, select *Options* and a menu option.

■ Time of call

You can make or receive up to five calls to or from the same number and view the time each call occurred. Your clock must be set for this feature to work accurately.

1. While viewing a missed, received, or dialed call, select *Options > Time of call*.
2. Scroll down to view the most recent call times from this number.
3. Select *Back* to return to the options list.

■ Use other options

Useful options exist when viewing a missed, received, or dialed call. Select *Options > Time of call, Send message, Use number, Save, Add to contact, Delete, or Call*.

■ View Message Recipients

You can view recipients of messages you have sent.

■ Clear log lists

You can delete any missed, dialed, or received calls from phone memory. In the standby mode, select *Menu > Log > Clear log lists > All call lists, Missed calls, Received calls, Dialed numbers, or Msg. recipients*.

■ Minibrowser calls

Minibrowser is a network service. See "Network services," p. 6, for more information. If your wireless service provider supports this feature, you can view the size or duration of sent or received data from the minibrowser.



Note: The actual invoice for calls and services from your service provider may vary, depending on network features, rounding off for billing, taxes and so forth.

In the standby mode, select *Menu > Log > Minibrowser calls* and one of the following options:

Last sent browser data—View the size (KB) of the last sent browser data.

Last received browser data—View the size (KB) of the last received data.

All sent browser data—View the size (KB) of all sent browser data.

All received browser data—View the size (KB) of all received browser data.

Last browser session—View the duration time of the last browser session.

All browser sessions—View the duration time of all browser sessions.

Clear all browser logs—Select *OK > Yes* to clear all browser logs.

5. Messaging



Your phone is capable of creating and receiving text, voice, and minibrowser messages. Check with your service provider to see what messaging is available for you.

■ Text messages

Text messaging is a network service. See "Network services," p. 6 for more information. If your wireless service provider supports this feature, you can send and receive text messages to compatible phones that are also subscribed to the service.

When composing text messages, check the number of characters allowed in the top right corner of the message. Using special (unicode) characters takes up more space. If there are special characters in your message, the indicator may not show the message length correctly. Before the message is sent, the phone will tell you if the message exceeds the maximum length allowed for one message. Also, you can make distribution lists that contain phone numbers and names from your contact list. See "Distribution lists," p. 29 for more information.



Note: When sending messages, your device may display *Message sent*. This is an indication that the message has been sent by your device to the message center number programmed into your device. This is not an indication that the message has been received at the intended destination. For more details about messaging services, check with your service provider.

Text message folders and options

In the standby mode, select *Menu > Messaging > Text messages* and from the following:

Create message—Create and send messages.

Inbox—Check for received text messages. Text messages are automatically stored in the *Inbox* when they are received. A notification appears when a message arrives in the *Inbox*.

Outbox—Check for outgoing text messages. Text messages are automatically stored in the *Outbox* as they are sent. If your service is interrupted while sending, the text message is stored in the *Outbox* until another delivery attempt is made.

Sent items—Sent text messages are stored in *Sent items*.

Drafts—View the list of messages saved for additional work.

Archive—View the list of saved messages for later reference.

Templates—Select from a collection of prewritten *Templates*, when creating text messages. Preloaded *Templates* can be edited and customized.

My folders—Create and name personal folders.

Distribution lists—Create and name lists of contacts for distribution of messages.

Delete messages—Delete messages from a selected folder or all folders.

Message settings—Change settings to read, write, and send text messages.

Write and send text messages

1. In the standby mode, select *Menu* > *Messaging* > *Text messages* > *Create message*.

To go quickly to the *Create message* screen, scroll left in the standby mode.

2. Compose a text message using the keypad. See "Select a text message option," p. 26, for options in composition.
3. Select *Send to* > *Recently used*, *Send to number*, *Send to e-mail*, *Send to many*, or *Send to distrib. list* (if you have created one).
4. Select a number or distribution list, enter the recipient's phone number or e-mail address, or select *Search* to retrieve a number or e-mail address from your contacts list; select *Send*.



Use a template

Templates are short, prewritten messages that can be retrieved and inserted into new text messages.

1. In the standby mode, select *Menu* > *Messaging* > *Text messages* > *Create message* > *Options* > *Use template*.
2. Select one of the available templates, and complete the text message using the keypad.

Read and reply to text messages

When you receive a text message, a notification appears and the unopened letter icon (✉) is displayed.

Messaging

1. Select *Show* to read the text message or *Exit* to dismiss the notification.
Scroll to view the whole message, if necessary.
When unopened messages are in your inbox,  is shown in the upper left corner in the standby mode as a reminder.
2. Select *Reply* > *Empty screen*, *Original text*, *Template*, or one of the predefined answers provided.
3. Compose your reply with the keypad, and select *Send*.

Select a text message option

Create message options

When you create or reply to a text message, depending on the mode of text input you use and the features supported by your wireless service provider, some or all of the following are available:

Sending options—Mark or Unmark a message as *Urgent*, *Delivery note*, *Callback no.*, or *Signature*.

Clear text—Erase all text from your message.

Insert contact—Insert detail from your contacts list into your message.

Insert number—Insert a phone number or find a phone number in the contacts list.

Move—Save the message in *Drafts*.

Exit editor—Exit the message editor.

Use template—Insert a predefined template.

Insert smiley—Insert a smiley.

Insert word or Edit word—Enter or edit the text of a new word that might not appear in the predictive text dictionary. This is displayed only when predictive text is on.

Insert symbol—Insert a special character. This is displayed only when predictive text is on.

Writing language—Select the language you want to use.

Prediction on or Prediction off—Turn predictive text on or off.

Matches—View matches found in the predictive text dictionary for the word you want to use. This is displayed only when predictive text is on and you are composing a word.

Read message options

When you read a text message, the following options are available:

Delete—Discard the text message.

Message details—View the details of the text message.

Use detail > Number, E-mail address, or Web address—Select *Save* to create a new contact; select *Options > Add to contact, Send message, or Call* for other options.

Move—Save the message to *Archive, Templates, or a folder you have created.*

Forward—Forward the text message to another phone number.

Lock or Unlock—Lock or unlock the text message. The appropriate option appears.

Rename—Edit the title of the text message.

Use custom folders

Your phone has a folder system that saves and stores text messages. Additionally you can create custom folders.

Create a custom folder

To organize your messages, create custom folders, and save messages you want to keep there.

1. In the standby mode, select *Menu > Messaging > Text messages > My folders > Add fold.* to create your initial custom folder.
Select *Menu > Messaging > Text messages > My folders > Options > Add folder* to create an additional custom folder.
2. Enter a name for the new folder, and select *OK*.

Rename a custom folder

1. In the standby mode, select *Menu > Messaging > Text messages > My folders.*
2. Scroll to the folder you wish to rename, and select *Options > Rename folder.*
3. Select and hold *Clear* to delete the existing entry; enter a new name for the folder; select *OK* to confirm or *Back* to exit.

Delete a custom folder

Only folders in *My folders* can be deleted. The *Inbox, Outbox, Sent items, Drafts, Archive, and Templates* folders are protected. When you delete a folder, all messages in the folder are also deleted.

1. In the standby mode, select *Menu > Messaging > Text messages > My folders.*
2. Scroll to the folder you wish to delete, and select *Options > Delete folder.*
3. Select *Yes* to delete or *No* to exit.

Delete text messages

If your message memory is full and you have more text messages waiting at the network,  blinks in the standby mode. You can do the following:

- Read some of the unread text messages, and delete them.
- Delete text messages from some of your folders.

Delete a single text message

To delete a single text message, you must open it.

1. In the standby mode, select *Menu > Messaging > Text messages*.
2. Select the folder containing the text message you wish to delete.
3. Select the message you wish to delete and *Options > Delete*.
4. Select *Yes* to delete the message or *No* to exit.

Delete all messages in a folder

1. In the standby mode, select *Menu > Messaging > Text messages > Delete messages* and one of the following:
 - All*—Deletes all text messages in the folder.
 - All read*—Deletes only the read text messages in the folder.
 - All unread*—Deletes all unread text messages in the *Inbox*.
2. If you select *All* or *All read*, select *Mark* or *Unmark* to select the folders from which to delete text messages. Select *Options > Mark all* to select all folders.
3. Select *Done* after choosing the folders.
4. Select *Yes* to delete the message or *No* to exit.

Text message settings

Sending options

In the standby mode, select *Menu > Messaging > Text messages > Message settings > Sending options*. Scroll to the setting or settings you wish to change:

Priority > Normal or *Urgent*—the priority of the message

Callback number > On—to send your default phone to the recipient

Signature—to append a signature to an outgoing text message. If you have not created a signature, select *On*; enter a signature, and select *OK*.

Other settings

In the standby mode, select *Menu > Messaging > Text messages > Message settings > Other settings* and the setting you wish to change:

Message font size—Select the desired font size for the display.

Message overwriting > *Sent items only*, *Inbox only*, *S. items & Inbox*, or *Off*—Set your phone to automatically replace old messages in *Inbox* or *Sent items* when new ones arrive. When the message memory is full, your phone cannot send or receive any new messages.

Save sent messages—Select *Always save* or *Always prompt* to save sent text messages to *Sent items*. Select *Off* to not save messages.

Auto-playback of sounds—If you have enhanced text messaging, select *On* or *Off* to control sound clips.

Queue msgs. when digital unavailable—Select *On* or *On prompt* to store text messages in the *Outbox* until they can be sent with a digital service. Select *Off* to not store messages.

■ Distribution lists

Distribution lists allow you to send messages to a designated group of people.

Create distribution lists

1. In the standby mode, select *Menu* > *Messaging* > *Text messages* > *Distribution lists* > *New list*.

If you create a second distribution list, select *Menu* > *Messaging* > *Text messages* > *Distribution lists* > *Options* > *Create new list*.

2. Enter a name for the list, and select *OK*.
3. To add a contact to this list, select *Add new*, and add the contacts one by one.

A distribution list only contains phone numbers of recipients.

Add and remove contacts

To add contacts, select *Menu* > *Messaging* > *Text messages* > *Distribution lists* > the list of choices > *Add new*. Add the contacts one by one.

To remove contacts, select *Menu* > *Messaging* > *Text messages* > *Distribution lists* > the list of choices > *Options*, and remove the contact name.

Use distribution lists

1. In the standby mode, select *Menu* > *Messaging* > *Text messages* > *Distribution lists*.
2. Scroll to the list you wish to modify; select *Options* and one of the following:
 - Create new list*—Create a new distribution list.
 - Send message*—Send message to the distribution list.
 - Rename list*—Rename the distribution list.

Messaging

Clear list—Clear the distribution list of all current contacts.

Delete list—Delete the distribution list.

■ Voice messages

If you subscribe to voice mail, your wireless provider will furnish you with a voice mailbox number. You need to save this number to your phone to use voice mail. When you receive a voice message, your phone will beep, display a message, or both. If you receive more than one message, your phone shows the number of messages received.

Save voice mailbox number

Your wireless provider may have already saved your voice mailbox number to your phone. If so, the number will appear in the display in step 2. Select *OK* to leave the number unchanged.

1. In the standby mode, select *Menu > Messaging > Voice messages > Voice mailbox number*.
2. If the number is not displayed or incorrect, enter your voice mailbox area code and number.
3. Select *OK*.

Call and set up your voice mail

After you save the voice mailbox, in the standby mode, press and hold 1. When you connect to voice mail and the prerecorded greeting begins, follow the automated instructions to set up your voice mail.

Listen to your voice mail

After you set up voice mail, you can dial the number in one of four ways:

- Dial the number.
- Press and hold 1.
- Select *Listen* if there is a notification on the display.
- In the standby mode, select *Menu > Messaging > Voice messages > Listen to voice messages*.

When you connect and the prerecorded greeting begins, follow the automated instructions to listen to your voice messages.

Automate voice mail

Voice mail services vary by service provider. The following instructions are examples of common operations. Please check with your service provider for specific instructions for using your voice mail service.

Write down number and process

1. Write down your voice mailbox number.
2. Call and check your voice mail as you normally would.
3. Write down your interaction with the recorded prompts step-by-step. Note that each voice mail service may vary. Your steps may resemble the following:
Dial 2145551212, pause 5 seconds, press 1, pause 2 seconds, press 1234, and press *.

Be precise; you will need this information in "Set up voice mail with dialing codes," p. 31.

Set up voice mail with dialing codes

1. In the standby mode, select *Menu > Contacts > 1-touch dialing*.
2. Scroll to an empty 1-touch dialing slot, and select *Assign*.
3. Enter your voice mailbox number, including the area code.
4. Refer to dialing codes, and enter any codes as necessary. Use the information that you saved from "Write down number and process," p. 31.

For example, if you pause for 5 seconds after connecting to voice mail, enter p twice after the voice mailbox number, for example, 2145551212pp. For more information on dialing codes see "Insert dialing codes," p. 33.

5. Enter any remaining pauses or other information that allows you to listen to your messages, and select *OK*.
6. Enter a name (such as voice mail), and select *OK*.

To dial and listen to your voice mail, press and hold the assigned 1-touch dialing key in the standby mode.

■ Minibrowser messages

Minibrowser messaging is a network service. See "Network services," p. 6 for more information.

If your wireless service provider supports this feature, you can check for e-mail messages using the minibrowser. In the standby mode, select *Menu > Messaging > Minibrowser messages > Connect*.



Important: Exercise caution when opening messages. E-mail messages may contain malicious software or otherwise be harmful to your device or PC.

6. Contacts



The contacts list can hold up to 500 contacts with multiple numbers and text notes for each contact. The amount of numbers and text entries that you can save may vary, depending on length and the total number of entries in the contacts list.

In the standby mode, select *Menu > Contacts* and from the following options:

Names—Display the list of contacts currently on your phone.

Settings—Change your contact settings.

Groups—Assign contacts to caller groups.

Voice tags—Assign voice commands to phone numbers.

1-touch dialing—Assign specific keys to phone numbers.

My number—Show the current number assigned to the phone.

Delete all contacts—Delete all contacts on your phone.

To quickly access your contacts scroll up or down while in the standby mode.

■ View contacts

In the standby mode, select *Menu > Contacts > Names*, or press the *Names* key. While viewing your contact list, you can select *Details* for the contact information or *Options* and one of the following:

Search—Search your contacts.

Add new—Add a new contact.

Add new group—Add a new caller group.

Delete contact—Delete the contact to which you have scrolled.

To make a call, scroll to a phone number for a contact, and select *Call*.

■ Search contacts

In the standby mode, select *Menu > Contacts > Names > Options > Search*. Enter the first character of the contact name, and scroll to the contact you wish to view.

If the right selection key on your phone is *Names*, you can select *Names > Options > Search* in the standby mode.

■ Add new contacts

Save a name and number

1. In the standby mode, enter the phone number you wish to save.
2. Select *Save*.
3. Enter the name, and select *OK > Done*.

When you enter a number, you can select *Options > Insert pause ('p')* to insert a pause code or *Options > Insert wait ('w')* to insert a wait code. See "Insert dialing codes," p. 33, for additional information.

Save a number (only)

In the standby mode, enter the phone number you wish to save, and select and hold *Options*..

Save a contact

1. In the standby mode, select *Menu > Contacts > Names > Options > Add new*.
2. Enter the name, and select *OK*.
3. Enter the phone number, and select *OK*.

Insert dialing codes

Insert special characters called dialing codes into phone numbers such as voice mail, and save the number to a *1-touch dialing* location. Dialing codes instruct the receiving system to pause, wait, bypass, or accept the numbers that follow them in the dialing string.

Automate voice mail with dialing codes. For more information, see "Automate voice mail," p. 30.

Press * repeatedly to cycle through dialing codes. When the desired code is displayed, pause briefly, and the code is inserted into the dialing string.

The following dialing codes are available:

Dialing code	Indicates...
*	Bypasses a set of instructions.
+	Causes the international access code to be replaced by +.
p	Pauses for 2.5 seconds before sending any numbers that follow.
w	Waits for you to press the call key before sending the numbers or codes that follow.

Save multiple numbers

You can save different types of phone numbers per contact. The first number you save for any entry is automatically set as the default, but the default number can always be changed.

1. In the standby mode, scroll down to display your list of contacts.
2. Select the contact to which you want to add a phone number.
3. Select *Details > Options > Add detail > Number > General, Mobile, Home, Work, or Fax.*
4. Enter the phone number, and select *OK.*

If you want to change the number type, scroll to the number, and select *Details > Options > Change type > General, Mobile, Home, Work, or Fax.*

Save other details

To add an address or a note to an existing contact, do the following:

1. In the standby mode, scroll down to display your list of contacts.
2. Scroll to the contact to which you want to add an address or note.
3. Select *Details > Options > Add detail > E-mail address, Web address, Street address, or Note.*
4. Enter the text for the note or address, and select *OK.*

To associate an image or tone to an existing contact, do the following:

1. In the standby mode, scroll down to display your list of contacts.
2. Scroll to the contact to which you want to add an address or a note.
3. Select *Details > Options > Add detail > Image* to save an image from the gallery or *Tone* to select the default tone or a new tone from the gallery.

Change default number

To change the default number for an existing contact.

1. In the standby mode, scroll down to display your list of contacts.
2. Select the contact for which you want to change the default number and *Details.*
3. Scroll to the new default number, and select *Options > Set as default.*

Send business cards

You can send a business card to a compatible phone or other handheld device.

1. In the standby mode, scroll down to display your list of contacts.
2. Select the contact to which you want send as a business card and *Details.*

3. Select the number to use and *Options > Send bus. card > Via text message or Via Bluetooth*.
4. Select *Primary number* or *All details* to send all the personal details that have been defined.
5. Enter the number for your recipient, or select *Search* to retrieve a number from your contacts; select *OK*.

■ Edit contacts

1. In the standby mode, scroll down to display your list of contacts.
2. Scroll to a contact, and select *Details*.
3. Scroll to the name, number, detail, or image you wish to edit; and select *Options*. The type of detail to which you scroll determines your selection of options. Select one of the following options:
 - View*—View the phone number of the contact.
 - Add detail > Name*—Add a name to the contact. This option appears only if the contact does not have a name.
 - Add detail > Number > General, Mobile, Home, Work, or Fax*—Add a number to the contact.
 - Add detail > E-mail address, Web address, Street address, Note, Image, or Tone*—Add an additional detail to the contact.
 - Edit name, Edit number, or Edit detail*—Edit the detail of the contact.
 - Change image*—Change the selected image associated with the contact.
 - Delete contact*—Delete the entire contact entry from your contacts.
 - Delete*—Delete the detail from this contact.
 - Send message*—Create and send a text message to the contact.
 - Use number*—Display the phone number, ready for use.
 - Set as default*—Make the number the default for the contact.
 - Change type > General, Mobile, Home, Work, or Fax*—Change the number type.
 - Add voice tag*—Add a voice tag to the contact.
 - Save to gallery*—Save the image to your *Gallery*.
 - Send bus. card > Via text message, or Via Bluetooth*—Send the contact as a business card to another phone.
 - Add to group*—Add the contact to a previously created call group.
 - 1-touch dialing*—Assign the contact to your 1-touch dialing list.

■ Modify contact settings

In the standby mode, select *Menu > Contacts > Settings* and the setting you wish to change:

Scrolling view—Select *Normal name list*, *Name and number*, *Large name list*, or *Name and image* view.

Memory status—View the amount of phone memory used as well as the amount of phone memory available.

■ Set up caller groups

You can add contacts to caller groups that you create and assign a unique ringing tone or graphic to each group. This enables you to identify callers from the group by their unique ringing tone or graphic.

Create a caller group

You can create a new caller group and store a list of contacts in the group.

In the standby mode, select *Contacts > Groups > Options > Add new group*; enter the name of the new group, and press *OK*.

Add a contact to a caller group

1. In the standby mode, press *Names*.
2. Scroll to a contact, select *Details*.
3. Scroll to a number and *Options > Add to group* and the existing caller group to which you wish to add the number.

Modify a caller group

In the standby mode, select *Menu > Contacts > Groups > Options > Group details* and one of the following options:

Group name—Rename the group to your preference.

Group ringing tone—Set the ringing tone for the group.

Group image—Turn the graphic for the caller group on or off.

Group members—Add or remove members from the caller group.

■ Set up voice tags

Before using voice tags, note the following:

- Voice tags are not language-dependent. They are dependent on the speaker's voice.

- You must say the name exactly as you said it when you recorded it.
- Voice tags are sensitive to background noise. Record voice tags, and use them in a quiet environment.
- Very short names are not accepted. Use long names, and avoid similar names for different numbers.



Note: Using voice tags may be difficult in a noisy environment or during an emergency, so you should not rely solely upon voice dialing in all circumstances.

Assign a voice tag

To use voice dialing, you must first assign a voice tag to a number.

1. In the standby mode, select *Names*.
2. Scroll to a contact, and select *Details*.
3. Scroll to the number you want to assign a voice tag, and select *Options > Add voice tag*.
4. Select *Start*, then speak clearly into the microphone. Do not select *Quit* unless you want to cancel the recording.
5. After you finish speaking, the phone automatically stops recording, saves, and replays the voice tag.

 appears next to the phone numbers which have voice tags assigned.

Use a voice tag

1. In the standby mode, select and hold *Names*.
2. When you hear several beeps and *Speak now* appears, release the key.
3. Pronounce the voice tag clearly into the microphone.

When the phone finds the voice tag, a notification appears, and the phone automatically dials the number. If the phone does not locate a number or recognize the voice tag, *No match found* appears.

Play back a voice tag

1. In the standby mode, select *Menu > Contacts > Voice tags*.
2. Scroll to the voice tag you want to play back, and select *Playback*.

Modify a voice tag

1. In the standby mode, select *Menu > Contacts > Voice tags*.
2. Scroll to the voice tag you want to change, and select *Change*.
3. Select *Start*, and speak clearly into the microphone. The phone repeats your voice tag, and *Voice tag changed* appears.

Delete a voice tag

1. In the standby mode, select *Menu > Contacts > Voice tags*.
2. Scroll to the voice tag you want to delete, and select *Delete*.
Delete voice tag? appears.
3. Select *Yes* to erase the voice tag.

■ Set up 1-touch dialing

You can associate any entry in your contacts with a key from 2 to 9; to dial those entries, press and hold the assigned key.

Assign a key to 1-touch dialing

1. In the standby mode, select *Menu > Contacts > 1-touch dialing*.
2. Scroll to any empty slot, and select *Assign*.
3. Enter the number (including the area code), and select *OK*; or select *Search* to retrieve a number from your contacts.
4. If necessary, enter the contact name for the number, and select *OK*.

If *1-touch dialing* is off, the phone displays a prompt asking if you want to activate *1-touch dialing*. Select *Yes* to activate *1-touch dialing*.

Change 1-touch dialing numbers

1. In the standby mode, select *Menu > Contacts > 1-touch dialing*.
2. Scroll to the *1-touch dialing* entry you wish to change, and select *Options > Change*.
3. Enter the new number, or select *Search* to retrieve a number from your contacts; select *OK*.
4. If necessary, enter the contact name for the number, and select *OK* to change the key assignment.

Delete 1-touch dialing numbers

1. In the standby mode, select *Menu > Contacts > 1-touch dialing*.
2. Scroll to the *1-touch dialing* location you wish to delete.
3. Select *Options > Delete > Yes* to delete the key assignment.

■ Display phone number

In the standby mode, select *Menu > Contacts > My number* to display your phone number.

■ Delete contacts

Delete individual contacts

1. In the standby mode, scroll down to display your list of contacts.
2. Scroll to a contact, and select *Options > Delete contact > Yes or No*.

Delete all contacts

1. In the standby mode, select *Menu > Contacts > Delete all contacts > Yes*.
2. Enter your lock code, and select *OK*. See "Security," p. 58 for more information.

7. Gallery



You can save pictures, video clips, recordings, music files, and ringing tones to folders in the *Gallery*, and add new folders to the ones already there. To download images and tones, use text messaging, mobile Internet sites, or Nokia PC Suite.

Your phone supports a digital rights management system to protect content that you have acquired. A piece of content, such as a ringing tone, can be protected and associated with certain usage rules, for example, the number of usage times or a certain usage period. The rules are defined in the content activation key that can be delivered with the content or separately, depending on the service provider. You may be able to update these activation keys. Always check the delivery terms of any content and activation key before acquiring them, as they may be subject to a fee.

Copyright protection may prevent some images, ringing tones, and other content from being copied, modified, transferred, or forwarded.

Your phone has about 12 MB of memory for storing files in the *Gallery*. This memory is not shared with other functions, such as contacts. If the phone displays a message that the memory is full, delete some existing files before proceeding.

■ Open a folder

In the standby mode, select *Menu > Gallery* to view the folder system. The phone folder system includes:

Games—A set of games included with your phone are stored here.

Tones—A set of ringing tones included with your phone are stored here.

Images—A set of images included with your phone are stored here.

Applications—A set of applications included with your phone or downloaded are stored here.

Messaging—Files used in messaging are stored here.

Your folders—Folders you create appear after the preset folders.

To open a folder, scroll to the folder, and select *Open*. Once you open the folder list and scroll to a file, you can access the file or the options associated with that specific file type.

■ Gallery options

In the standby mode, select *Menu > Gallery > Options* and one of the following:

Memory status—Check the available memory for the phone handset.

Get new—Download new content from your provider.

8. Media



■ Recorder

The recorder allows you to make a short (up to 3 minutes) recording and save it to the *Recordings* folder or another folder in the *Gallery*. The recorder cannot be used when a data call is active.

Record speech or sound

1. In the standby mode, select *Menu > Media > Recorder*.
2. To start the recording, select the red record virtual button.
3. Hold the phone in the normal position near your ear, and record your message.
4. When you are finished recording, select the green stop virtual button.

The recording is given a default name and saved to the *Recordings list*. The default location of the *Recordings list* is the *Tones* folder in the *Gallery*.

After you have made a recording, select *Play last recorded* to replay the recording and *Send last recorded* to send the recording to a compatible phone using Bluetooth. These options are only available during the current recording session.

Recording list

1. In the standby mode, select *Menu > Media > Recorder > Recordings list, Tones*.
2. Navigate through the *Tones* folder, and select a recording you want to modify.
3. Select *Open* to open and play the recording, or select *Options*.

9. Settings



Use the *Settings* menu to change profiles, display settings, themes, tone settings, time and date settings, call settings, phone settings, voice commands, connectivity, enhancements, security settings, application settings, network settings, network services, restore factory settings, and view phone details.

■ Profiles

Profiles define how your phone reacts when you receive a call or message, how your keypad sounds when you press a key, and more. Ringing options, keypad tones, and other settings for each of the available profiles can be left at their default setting, or customized to suit your needs. The following profiles are available: *Normal*, *Silent*, *Meeting*, *Outdoor*, and two customizable profiles.

Profiles are also available for enhancements such as a headset and car kit. See "Enhancement settings," p. 56.

Activate a profile

In the standby mode, select *Menu > Settings > Profiles > Normal, Silent, Meeting, Outdoor*, or custom profile *> Activate*.

Customize a profile

To modify a profile, in the standby mode, select *Menu > Settings > Profiles > Normal, Silent, Meeting, Outdoor, Pager*, or custom profile *> Customize >* and a profile option. You cannot rename the *Normal* profile. To customize profile tones, see "Tones," p. 48.

Set a timed profile

Timed profiles can be used to prevent missed calls. For example, suppose you attend an event that requires your phone be set to *Silent* before the event starts, but you forget to return it to *Normal* until long after the event. A timed profile can prevent missed calls by returning your phone to the default profile at a time you specify.

To set a timed profile, do the following:

1. In the standby mode, select *Menu > Settings > Profiles > Normal, Silent, Meeting, Outdoor*, or custom profile *> Timed*.
2. Enter the time for the profile to expire, and select *OK*.

Timed profiles can be set up to 24 hours in advance.

■ Display

Your phone has two displays: a main display inside the cover and a mini display outside the cover.

Power saver

When this feature is enabled, the display shows only a simplified display after a time-out period. In the standby mode, select *Menu > Settings > Display > Main display* or *Mini display > Power saver > On* or *Off*

Standby mode settings

You can select settings for the display of the standby screen on the main display.

Wallpaper

You can set either an *Image* or a *Slide set* as wallpaper for the phone display.

In the standby mode, select *Menu > Settings > Display > Main display > Standby mode settings > Wallpaper* and one of the following:

On—Activate wallpaper on your phone.

Off—Deactivate wallpaper on your phone.

Image—Select an image from the *Gallery* for wallpaper. Select *Open* to browse the *Images* folder. Select the image of your choice for the wallpaper.

Font color

You can set font color of your phone when in standby mode, in the standby mode, select *Menu > Settings > Display > Main display > Standby mode settings > Standby mode font color*. Scroll to select a color from the color grid.

Screen saver

You can select a screen saver for the main display. In the standby mode, select *Menu > Settings > Display > Main display > Screen saver* and one of the following:

On—Activate screen saver on your phone.

Off—Deactivate screen saver on your phone.

Screen savers > Image, Video Clip, or Digital clock—Select an image, video clip or other option to act as your screen saver.

Time-out—Modify the idle time before the screen saver activates.



Note: Power saver is automatically activated after the time-out of the screen saver to optimize battery life.

Banner

If your wireless service provider supports this feature, you can select whether the display shows the operator logo or a custom banner, when the phone is in the standby mode. In the standby mode, select *Menu > Settings > Display > Main display > Banner > Default or Customize*.

Sleep mode

Sleep mode is a power-saving feature that turns the phone display off during inactivity. You can activate the sleep mode feature on your phone. In the standby mode, select *Menu > Settings > Display > Main display or Mini display > Sleep mode > On or Off*.

When *Sleep mode* is activated the display is completely blank. A blinking LED indicator shows that the phone is still on.

Backlight time-out

You can control the time-out of the backlight on your phone. In the standby mode, select *Menu > Settings > Display > Main display or Mini display > Backlight time-out*.

Themes

Themes allows you to personalize the ringtone, screensaver and background on your phone. In the standby mode, select *Menu > Settings > Display > Themes > Select theme* and the theme of your choice.

■ Connectivity

You can also connect the phone to a compatible PC using a USB data cable; and use the phone as a modem to enable connectivity from the PC.

For more information, see the Nokia PC Suite online help. Nokia PC Suite and all related software can be downloaded from the U.S. Mobile Phone products section of www.nokiausa.com/pcsuite.



Important: only install and use applications and other software from sources that offer adequate security and protection against harmful software.

Bluetooth connectivity

Bluetooth technology connectivity enables cost-free wireless connections between electronic devices and can be used to send and receive images, texts, gallery files, voice recordings, video clips, notes, business cards, and calendar notes. It can also be used to connect wirelessly to products that use Bluetooth wireless technology, such as computers. You can synchronize your phone and your PC using Bluetooth connectivity.

Since devices with Bluetooth connectivity communicate using radio waves, your phone and the other device do not need to be in direct line-of-sight.

The two devices only need to be within a maximum of 30 feet (10 meters) of each other. The connection can be subject to interference from obstructions such as walls or other electronic devices.

The Bluetooth wireless technology application whether used actively or in the background, consumes the battery and reduces the operating time of the phone.

This device is compliant with Bluetooth Specification 1.2 and supports the following profiles:

- Object push profile (OPP)
- File transfer profile (FTP)
- Dial-up networking profile (DUN)
- Generic object exchange profile (GOEP)
- Headset profile (HSP)
- Hands-free profile (HFP)
- Generic access profile (GAP)
- Service Discovery Protocol (SDP)
- Serial port profile (SPP)

To ensure interoperability between other devices supporting Bluetooth technology, use only enhancements approved by Nokia for this model. Check with the manufacturers of other devices to determine their compatibility with this device.

There may be restrictions on using Bluetooth technology in some locations. Check with your local authorities or service provider. If you want more information on this function, visit the Bluetooth Technology organization website:

<https://www.bluetooth.org/>.

Pairing

You can set up a permanent association (pairing) between your phone and another device with Bluetooth technology. Some devices may require pairing before data transfer can take place.

To pair with a device, you and the owner of the other device must agree on a pass code of 1–16 numeric characters. The first time you try to connect the devices, you must each enter the same pass code. Once the devices are paired, you will not need to use the pass code again, so there is no need to remember it.

Paired devices are placed in your paired device list. You can view the list even when Bluetooth connectivity is not active or when the devices in the list are not available for connection.

Settings

In the standby mode, select *Menu > Settings > Connectivity > Bluetooth > Paired devices > Options* and one of the following:

Assign short name—Give a nickname to the selected device (visible to you only).

Auto-conn. without confirmation—Select *No*, if you want the phone to connect to the selected device automatically or *Yes*, if you want the phone to ask for your permission first.

Delete pairing—Delete the pairing to the selected device.

Pair new device—Search for active devices with Bluetooth technology within range, scroll to the desired device, and select *Pair* to establish pairing with that device. Do not accept Bluetooth connectivity from sources you do not trust.

Bluetooth connectivity settings

You can define how your phone is shown to other devices with Bluetooth connectivity.

In the standby mode, select *Menu > Settings > Connectivity > Bluetooth > Bluetooth settings* and one of the following:

My phone's visibility—Select *Shown to all* to show the phone to all other devices with Bluetooth connectivity or *Hidden* to show the phone only to the paired devices. Operating the phone in hidden mode is a safer way to avoid malicious software.

My phone's name—Change your phone name that is seen by other users.

Set up a connection

1. In the standby mode, select *Menu > Settings > Connectivity > Bluetooth > On*. The active Bluetooth technology connection is indicated by  at the top of the display.
2. Select *Search for audio enhancements* to search for compatible devices with Bluetooth connectivity. The list of found devices appears in the display.
3. Select the desired device. If required, enter the Bluetooth connectivity pass code of the device to complete the pairing.
4. If required, enter the Bluetooth connectivity pass code of the device to pair with the device.

Your phone connects to the device. You can start data transfer.

To view the device you are connected to, select *Menu > Settings > Connectivity > Bluetooth > Active device*.

To deactivate Bluetooth connectivity, select *Menu > Settings > Connectivity > Bluetooth > Off*. Deactivation of the Bluetooth technology connection will not affect other functions of the phone.

Send data

Instead of using the *Connectivity* menu, you can use other phone menus to send various types of data to other devices with Bluetooth connectivity. For example, you can send a video clip from the *Video clips* folder of the *Gallery* menu. See the appropriate sections of the user guide for information about sending different types of data.

Receive a data transfer

When a Bluetooth technology connection is active in your phone, you can receive notes, business cards, video clips, and other types of data transfers from another device with Bluetooth connectivity. When you receive a data transfer, an alarm sounds, and a message appears in the start screen.

To view the transferred item immediately from the standby mode, select *Show*. To view the item at a later time, select *Exit*.

Depending on the nature of the item, it is saved in the appropriate menu in your phone. For example, a business card would be saved in *Contacts*, and a calendar note would be saved in *Calendar*.

Data cable transfer

To transfer data from your phone to a compatible PC or from a compatible PC to your phone, use a CA-53 USB data cable.



Important: Disconnect the USB data cable from the phone to make a call.

Enable default mode connection

Connect to your PC in *Default mode* to transfer phone data and files between your phone and PC using PC Suite.

1. Connect your PC and your phone with a CA-53 USB data cable. A notification is displayed that asks which mode you want to select.
2. Select *Accept > Default mode*. A notification is displayed stating that a connection is active.

You can now use PC Suite to connect to your phone.

Disable data storage connection

1. To disable the USB data cable, double-click the green arrow on the task bar at the bottom of your PC screen.

A window pops up that shows **Unplug** or **Eject Hardware**.

2. Click on USB Device in the Hardware devices window.

A popup window shows **Stop a Hardware device**.

Settings

3. Scroll to **USB device**, and click **OK**.

A popup window is displayed with a message that says it is safe to disconnect the device.

4. Click **OK**.

Data and fax transfer

You can make data and fax transfers during a phone call. For more information, see "Data and fax transfer," p. 48.

■ Tones

You can adjust the ringing volume, keypad tones, and more for the active profile. In the standby mode, select *Menu > Settings > Tones* and one of the following:

Incoming call alert—Select how your phone will alert you when there is an incoming call: *Ring*, *Ascending*, *Ring once*, *Beep once*, *Off*.

Ring tone—Select *Open Gallery > Tones* to select the ringing tone for incoming calls.

Incoming call video > Off or *Incoming call video*—Select a video clip to be displayed when you receive an incoming call.

*Ring*ing volume—Use the left and right scroll keys to set the volume of your ringing tone.

Vibrating alert—Activate the vibrating call alert. Select *On* to activate the vibrating alert.

Message alert tone—Select the alert tone for incoming messages: *Off*, *Standard*, *Special*, *Beep once*, *Long & loud*, *Ring*ing tone.

Keypad tones—Scroll to set the volume of your keypad tones (or turn them off).

Warning tones—Turn warning and confirmation tones on or off

Alert for—Set the phone to alert only when a member of a selected caller group calls. See "Set up caller groups," p. 36 for more information.

■ Time and date

Clock

Show or hide the clock

In the standby mode, select *Menu > Settings > Time and date > Clock > Show clock* or *Hide clock*.

Set the time

1. In the standby mode, select *Menu > Settings > Time and date > Clock > Set the time*.
2. Enter the time (in hh:mm format), and select *OK*.
3. Select *am* or *pm* (this option is displayed only when 12-hour format is in use).

Change the time zone

In the standby mode, select *Menu > Settings > Time and date > Clock > Time zone* and your time zone based on Greenwich Mean Time (GMT), plus or minus hours in your time zone.

For example, GMT-8 is US Pacific time in Los Angeles, CA. GMT does not include Daylight savings time, so add or subtract accordingly.

Change the format

In the standby mode, select *Menu > Settings > Time and date > Clock > Time format > 24-hour* or *12-hour*.

Date

Show or hide the date

In the standby mode, select *Menu > Settings > Time and date > Date > Show date* or *Hide date*.

Set the date

In the standby mode, select *Menu > Settings > Time and date > Date > Set the date*, enter the date, and select *OK*.

Change the format

1. In the standby mode, select *Menu > Settings > Time and date > Date > Date format* and the format of your choice.
2. With *Date* displayed select *Date separator*, and the separator of your choice.

Auto-update of date and time

Auto-update is a network service. See "Network services," p. 6, for more information.

If your wireless service provider supports this feature, you can allow the digital network to set the clock, which is useful when you are out of your home area (for example, when you have traveled to another network or time zone).

In the standby mode, select *Menu > Settings > Time and date > Auto-update of date & time > On, Confirm first, or Off*.

Settings

If you use the *Auto-update of date & time* option while outside your digital network, you may be prompted to enter the time manually. Network time will replace the time and date when you reenter your digital network.

You may be prompted to enter the time manually, if the battery is removed or discharged while you are outside the digital network and the battery is installed or recharged while you are still outside of the digital network.

■ Call

Location info sharing

Location info sharing sets whether your GPS location is always reported or reported only during an emergency call.

In the standby mode, select *Menu > Settings > Call > Location info sharing > 911 only* or *Location on*.

GPS should not be used for precise location measurement, and you should never rely solely on location data from the GPS receiver.

This feature is not designed to support positioning requests for related calls. Contact your service provider for more information about how your phone complies with government regulations on location based emergency calling services.

Anykey answer

When *Anykey answer* is on, briefly press any key except the right selection or end key to answer a call. In the standby mode, select *Menu > Settings > Call > Anykey answer > On* or *Off*.

Automatic redial

Occasionally, your network may experience heavy traffic, resulting in a fast busy signal when you dial. With automatic redial activated, your phone redials the number, and notifies you once the network is available.

In the standby mode, select *Menu > Settings > Call > Automatic redial > On* or *Off*.

1-touch dialing

To activate or deactivate *1-touch dialing*, in the standby mode, select *Menu > Settings > Call > 1-touch dialing > On* or *Off*. For more information on *1-touch dialing*, see "Set up 1-touch dialing," p. 38.

Answer when fold is opened

Set your phone to answer a call when you open the fold. If the setting is off, you must press the call key after you open the fold. In the standby mode, select *Menu > Settings > Call > Answer when fold is opened > On* or *Off*.

Automatic update of service

If supported by your wireless service provider, this feature allows you to set your phone to automatically receive updates from your network that may improve service and coverage. In the standby mode, select *Menu > Settings > Call > Automatic update of service > On or Off*.

Calling cards

If you use a calling card for long distance calls, save the calling card number in your phone. The phone can store up to four calling cards. Contact your calling card company for more information.

Save information

1. In the standby mode, select *Menu > Settings > Call > Calling card*.
2. Enter your security code, and select *OK*. See "Security," p. 58.
3. Scroll to the calling card of your choice, and select *Options > Edit > Select > Dialing Sequence*.
4. Select one of the following sequence types:
 - Access no.+phone no.+card no.*—Dial the access number for the calling card, the phone number, then enter the card number (plus PIN if required).
 - Access no.+card no.+phone no.*—Dial the access number for the calling card, card number (plus PIN if required), then enter the phone number.
 - Prefix+phone no.+card no.*—Dial the prefix (numbers that must precede the phone number) and phone number, then enter the card number (plus PIN if required).
5. Enter the required information (access number or prefix and card number), and select *OK* to confirm your entries.
6. Select *Card name > enter the card name > OK*.

Select a calling card

You can select one of the calling cards for which you have saved information. The selected card information is used when you make a card call.

1. In the standby mode, select *Menu > Settings > Call > Calling card*.
2. Enter your security code, and select *OK*. See "Security," p. 58.
3. Scroll to the calling card of your choice, and select it.

Make card calls

After you have selected a calling card, make a card call.

Settings

1. Enter the phone number, including any prefix (such as **0** or **1**) that your calling card may require when you make a calling card call. See your calling card for instructions.
2. Press and hold the send key for a few seconds until *Card call* is displayed.
3. Follow the instructions on the screen.
4. When you hear the tone or system message, select *OK*.

International prefix

If supported by your service provider, you can store an international prefix into your phone. When you enter + at the beginning of a phone number, your phone automatically inserts the international prefix that you have stored.

Store an international prefix

1. In the standby mode, select *Menu > Settings > Call > International prefix*.
2. Enter the international prefix (for example, 011), and select *OK*.

Use the international prefix

In the standby mode, enter + and the phone number you want to call, for example, +33934546789.

The phone dials the international prefix you have stored in your phone and the phone number you have entered. In the example, the phone dials 011.33.9.3454.6789.

Call summary

Your phone can display the time spent on a call when you hang up. In the standby mode, select *Menu > Settings > Call > Call summary > On or Off*.

Show call time on display

Your phone can display the call time during the phone call. In the standby mode, select *Menu > Settings > Call > Show call time on display > On or Off*.

Ringling tone for no caller ID

You can select a different ringing tone for calls received with no caller ID. In the standby mode, select *Menu > Settings > Call > Ringling tone for no caller ID > On or Off*. See "Customize a profile," p. 42 for more information on selecting a ringing tone.

■ Phone

Language settings

Phone language allows you to set the language of the display text seen on the phone. In the standby mode, select *Menu > Settings > Phone > Phone language* and the language of your choice.

My shortcuts

You can change the information displayed when you press the right selection key. In the standby mode, select *Menu > Settings > Phone > My shortcuts*. Select a shortcut and a choice.

Automatic keyguard

Automatic keyguard allows you to automatically lock your phone after a defined time. In the standby mode, select *Menu > Settings > Phone > Automatic keyguard > On or Off*.

Navigation key

If supported by your wireless service provider, you can set the features that are activated when you press the scroll key.

1. In the standby mode, select *Menu > Settings > Phone > Navigation key*.
2. Scroll to the scroll up, scroll down, scroll right, or scroll left arrow; select *Change*.
3. Select a function to assign to the action.

Touch tones

Touch tones are the tones that sound when you press the keys on your phone keypad. You can use *Touch tones* for many automated dial-up services such as banking and airlines or for entering your voice mailbox number and password.

Touch tones are sent during an active call. You can send them manually from your phone keypad, or send them automatically by saving them in your phone.

Set type

In the standby mode, select *Menu > Settings > Phone > Touch tones > Manual touch tones* and one of the following:

Continuous—The tone sounds for as long as you press and hold a key.

Fixed—Use to send tones of the duration you specify in the *Touch tone length* option.

Off—Use to turn off tones. No tones are sent when you press a key.

Set length

You can specify touch tone length when using the *Fixed* option. In the standby mode, select *Menu > Settings > Phone > Touch tones > Touch tone length > Short* (0.1 seconds) or *Long* (0.5 seconds).

Start-up tone

If the *Start-up tone* is activated, the tone sounds when you turn on your phone. In the standby mode, select *Menu > Settings > Phone > Start-up tone > On or Off*.

Help text activation

Your phone displays brief descriptions for most menu items. When you arrive at a feature or menu, pause for about 15 seconds and wait for the help text to display. Scroll to page through the full help text, if necessary.

The default setting for help text is on. However, you can turn help text on or off. In the standby mode, select *Menu > Settings > Phone > Help text activation > On or Off*.

Phone details

You can view information about your phone. In the standby mode, select *Menu > Settings > Phone > Phone details > User details, Version details, System details, or Icon details*.

Phone software updates

You can obtain the current version number of the software installed on your phone. If your service provider supports it, you can also obtain over-the-air software updates. In the standby mode, select *Menu > Settings > Phone > Phone software updates > Updates or Current version*.

■ Network

The menu options you see in your phone are based on your service provider's network. The network determines which options actually appear in the phone menu. Check with your service provider for more information.

The *Network* menu customizes the way your phone selects a network in which to operate while you are within or outside of your primary or home system. Your phone is set to search for the most cost-effective network. If your phone cannot find a preferred network, it selects a network automatically based on the option you select in the *Network* menu.

Roaming options

If supported by your wireless service provider, you can select which roaming option you wish to use. In the standby mode, select *Menu > Settings > Network > Roaming options* and one of the following:

Home only—You can make and receive calls in your home area only.

Automatic—The phone automatically searches for service in another digital network. If one is not found, the phone uses analog service. The roaming rate applies when not in the home service area.

Mode

If supported by your wireless service provider, you can select whether your phone will use digital or analog service. In the standby mode, select *Menu > Settings > Network > Mode* and one of the following:

Digital preferred—You prefer to make calls on a digital network, but will find another network, if necessary.

Analog only—You can make and receive calls on an analog network only.

■ Other settings

Voice commands

You can set up to five *Voice commands*, which allow hands-free operation of certain phone features.

Add a voice tag

Before using *Voice commands*, you must first add a voice tag to the phone function.

1. In the standby mode, select *Menu > Settings > Other settings > Voice commands*.
2. Select a function option you wish to tag, and select *Add*.
3. Select *Start*, and speak the voice tag clearly into the microphone.

Do not select *Quit* unless you want to cancel the recording.

The phone replays then saves the recorded tag.  appears next to the function option for which you add a voice tag.

Activate a voice command

After you have associated a voice command tag with a phone function, you can issue a command by speaking the voice command tag.

1. In the standby mode, select and hold *Names*.
2. When *Speak now* appears, pronounce the voice tag clearly into the microphone.

Settings

When the phone finds the voice command tag, *Found:* appears, and the phone plays the recognized voice command tag through the earpiece. The function you requested is activated.

Voice command options

You can modify voice command tags. In the standby mode, select *Menu > Settings > Other settings > Voice commands*, scroll to the voice command tag, and select one of the following options:

Playback—Listen to the voice command tag.

Options > Change—Change the voice command tag.

Options > Delete—Erase the voice command tag.

Application settings

The *Application settings* menu changes game and application settings.

In the standby mode, select *Menu > Settings > Other settings > Application settings* and one of the following:

Application tones > On or Off—Play sounds during an application.

Application lights > App. defined or Default—Play lights during an application.

Application vibration > On or Off—Vibrate phone during an application.



Warning: Use of vibration can aggravate injuries. Do not turn vibration on if you have any ailment in the bones or joints of your fingers, hands, wrists, or arms.

Enhancement settings

The *Enhancements* menu displays the hearing aid compliant option by default, but shows other options only if the phone is or has been connected to a compatible enhancement type.

Headset

In the standby mode, select *Menu > Settings > Other settings > Enhancements > Headset* and one of the following:

Default profile—Select the profile you wish to be automatically activated when a headset is connected.

Automatic answer—Calls are answered automatically after one ring when a headset is connected. Select *On* or *Off*.

Handsfree

In the standby mode, select *Menu > Settings > Other settings > Enhancements > Handsfree* and one of the following:

Default profile—Select the profile you wish to be automatically activated when a car kit is connected.

Automatic answer—Calls are answered automatically after one ring when a car kit is connected. Select *On* or *Off*.

Lights—Select to keep the phone lights always on, or to shut off automatically after several seconds. Select *On* or *Automatic*.

Loopset

A LPS-4 Loopset accessory allows your device to optimize sound quality when coupled with a hearing aid that is set to T-coil mode.

In the standby mode, select *Menu > Settings > Other settings > Enhancements > Loopset > Use Loopset > Yes* or *No*.

If the *Loopset* is connected and recognized through the Pop-Port™ connector, the phone automatically uses the *Loopset*.

TTY/TDD

Check with the manufacturer of the TTY/TDD device for a connecting cable that is compatible with your phone. TTY/TDD communications depend on network availability. Check with your service provider for availability and description of services.

In the standby mode, select *Menu > Settings > Other settings > Enhancements > TTY/TDD > Use TTY > Yes* or *No*.

Charger

In the standby mode, select *Menu > Settings > Other settings > Enhancements > Charger* and one of the following:

Default profile—Select the profile you want to automatically activate when your phone is connected to the charger.

Hearing aid

To optimize sound quality, you can set your phone to couple to a T-coil-equipped hearing aid.

In the standby mode, select *Menu > Settings > Other settings > Enhancements > Hearing aid > T-coil hearing aid mode*. Select **On** to activate the HAC. Verify that the hearing aid is set to T-coil mode, and hold the phone against the ear.

Only activate the *T-coil hearing aid mode* when using your device with a hearing aid or it may impact the audio performance of the device.

Security

To access *Security* for the first time, you must enter the preset lock code. By default, the security and lock codes are set to the last four digits of your phone number or 0000. If this does not work, contact your wireless service provider for help.

Phone lock

The phone lock feature protects your phone from unauthorized outgoing calls or unauthorized access to information stored in the phone. When phone lock is activated, *Phone locked* is displayed each time you turn your phone on.

When the device is locked, you can still call the official emergency number programmed into your phone.

1. In the standby mode, select *Menu > Settings > Other settings > Security*.
2. Enter the lock code, and select *OK*.
3. Select *Phone lock* and one of the following:
 - Off*—Immediately turns off the phone lock feature.
 - Lock now*—Immediately turns on the phone lock feature.
 - On power-up*—Turns on the phone lock feature the next time you turn the phone on.

If you select *Lock now*, you must enter your lock code before the phone will function normally. After the lock code is accepted, your phone functions normally.

Call not allowed appears if you attempt to place a call while your phone is locked.

To answer a call with phone lock on, select *Answer*, or press the call key.

Allowed number when phone locked

With phone lock on, the only outgoing calls you can make are to the emergency number programmed into your phone and the numbers stored in the *Allowed no. when phone locked* location.

1. In the standby mode, select *Menu > Settings > Other settings > Security*.
2. Enter the lock code, and select *OK*.
3. Select *Allowed no. when phone locked > Assign* and one of the three slots.
4. Enter the phone number, or select *Search* to retrieve the number from the phone book; select *OK*.

To place a call to an allowed number when the phone is locked, enter the allowed number and press the call key.

Change lock code

When changing the lock code, avoid using codes similar to emergency numbers such as 911 to prevent accidental dialing of an emergency number.



Note: If you enter the wrong lock code five times in succession, your phone will either not accept your current lock code for 5 minutes (even if you switch off the phone between attempts) or will switch off.

To change the phone lock code, do the following:

1. In the standby mode, select *Menu > Settings > Security*.
2. Enter the current lock code, and select *OK*.
3. Select *Change lock code*.
4. Enter the new lock code (only 4 characters), and select *OK*.
5. Enter the new lock code again for verification, and select *OK*.

When you change your lock code, make sure to remember it. If necessary, write it down and store it in a safe place away from your phone.

Call restrictions

Call restrictions allows you to block or permit numbers for incoming or outgoing calls.

1. In the standby mode, select *Menu > Settings > Other settings > Security*.
2. Enter the lock code, and select *OK*.
3. Select *Call restrictions* and the type of calls you wish to restrict:
 - Restrict outgoing calls*—Set restrictions on making calls.
 - Restrict incoming calls*—Set restrictions on receiving calls.
4. Select whether to block or allow numbers:
 - Blocked numbers*—Set numbers that are blocked on incoming calls, allowing all other numbers. When a number is blocked, the call is sent to voice mail.
 - Allowed numbers*—Set numbers that are allowed, blocking all other numbers.
5. To modify the restriction list, select from the following options:
 - Select*—Add numbers to the restriction list.
 - Add restriction*—Add a restriction to a number (unavailable if memory is full).
 - Edit*—Edit a restriction on a number.
 - Delete*—Delete a number from restriction list.

When calls are restricted, calls may be possible to the official emergency number programmed into your device.

Settings

Voice privacy

Voice privacy is a network service, and its function depends on a variety of services. Contact your service provider for more information.

If your wireless service provider supports this feature, the voice privacy feature protects the privacy of your current phone conversation from other callers placing phone calls on your same network.

1. In the standby mode, select *Menu > Settings > Other settings > Security*.
2. Enter the lock code, and select *OK*.
3. Select *Voice privacy > On or Off*.

Network services

The following features are network services. See also "Network services," p. 6.

Call forwarding

Call forwarding tells your network to redirect incoming calls to another number. *Call forwarding* is a network service and may not work the same in all networks, so contact your wireless provider for availability and information.

To activate, do the following:

1. In the standby mode, select *Menu > Settings > Network services > Call forwarding* and one of the following:
 - Forward all calls*—Forwards all calls to the number you specify.
 - Forward if busy*—Forward incoming calls when you are in a call.
 - Forward if not answered*—Forward incoming calls to another number if you are unable to answer. You can set a delay before forwarding takes place.
 - Forward if out of reach*—Forward incoming calls when your phone is off.
2. Select *Activate*.
3. Enter the number to which your calls, data, or other information are forwarded, and select *OK*.

To cancel, in the standby mode, select *Menu > Settings > Network services > Call forwarding > Cancel*.

Canceling call forwarding may affect your ability to receive voice mail messages. Contact your wireless provider for specific details.

Call waiting

If your wireless provider supports this feature, call waiting notifies you of an incoming call even while you are in a call. You can accept, reject, or ignore the incoming call.

To activate, in the standby mode, select *Menu > Settings > Network services > Call waiting > Activate*.

During a call, select *Answer* or press the call key to answer the waiting call. The first call is put on hold. Press the end key to end the active call.

To cancel, in the standby mode, select *Menu > Settings > Network services > Call waiting > Cancel*.

Send my caller ID

If your wireless service provider supports this feature, you can prevent your number from appearing on the receiving party's caller ID. In the standby mode, select *Menu > Settings > Network services > Send my caller ID > Yes or No*.

Store a feature code

Network feature setting allows you to activate network services in your phone using feature codes received from your service provider.

1. In the standby mode, select *Menu > Settings > Network services > Network feature setting*.
2. Enter the feature code from your service provider (for example, *900 for activating *Forward if busy*), and select *OK*.
3. Select *Call forwarding*.
4. Scroll to the type of forwarding that matches the feature code you entered (for example, *Forward if busy*), select *Activate*.

The activated feature code is now stored in your phone, and you are returned to the *Feature code:* prompt. Continue entering other feature codes or press the end key to return to the standby mode.

When you enter a network feature code successfully the feature becomes visible in the *Network services* menu.

My number selection

In the standby mode, select *Menu > Settings > Network services > My number selection*. This feature is carrier dependent.

Restore factory settings

You can reset some of the menu settings to their original values. Data that you have entered or downloaded is not deleted (for example, entries in your contacts list are not affected).

1. In the standby mode, select *Menu > Settings > Other settings > Restore settings*.
2. Enter the lock code, and select *OK*.



Note: Depending on your wireless service provider, your device may request the security code (defaulted to 12345) instead of the lock code.

10. Organizer



Your phone contains features to help organize your everyday life, including an alarm clock, calendar, calculator, countdown timer, and stopwatch.

■ Alarm clock

Set an alarm

The alarm clock is based on the phone clock. It sounds an alert any time you specify and even works if the phone is turned off.

1. In the standby mode, select *Menu > Organizer > Alarm clock > Alarm time*.
2. Enter the time for the alarm (in hh:mm format), and select *OK*.
3. Select *am* or *pm* if 12-hour clock format is on.

Alarm on appears briefly in the display, and  appears in the standby mode.

If you need to reset the alarm, select *Menu > Organizer > Alarm clock > Alarm time > On* from the standby mode.

To turn off the alarm, select *Menu > Organizer > Alarm clock > Alarm time > Off* from the standby mode.

Repeat alarm

You can set the alarm to repeat every day or only on certain days of the week.

1. In the standby mode, select *Menu > Organizer > Alarm clock > Repeat alarm > On*.
2. Check the day or days of the week you wish to repeat the alarm, and select *Mark*. Select *Unmark* to remove a day.
3. Select *Done* when you have added all desired days.

If you need to revise the days for a repeated alarm, select *Menu > Organizer > Alarm clock > Repeat alarm > Repetition days* from the standby mode.

If you need to stop a repeated alarm, select *Menu > Organizer > Alarm clock > Repeat alarm > Off* in the standby mode.

Set the alarm tone

You can set which tone is played when the alarm sounds.

Organizer

In the standby mode, select *Menu > Organizer > Alarm clock > Alarm tone* and one of the following:

Standard—Select the default alarm.

Open Gallery—Select a tone from the *Gallery* as the alarm.

Set the snooze time-out

You can set the *Snooze time-out* for the alarm.

In the standby mode, select *Menu > Organizer > Alarm clock > Snooze time-out* and select a snooze time.

When the alarm sounds, your phone beeps, vibrates (if vibrate alert is on in the currently active profile), and lights up.

With the phone on, select *Stop* to shut the alarm off or *Snooze*. If you select *Snooze*, the alarm stops for 10 minutes.

If you do not press a key, the alarm stops (snoozes) for the *Snooze time-out*, then sounds again.

If the alarm time is reached while the phone is switched off, the phone switches itself on and starts sounding the alarm tone. If you select *Stop*, the device asks whether you want to activate the phone for calls. Select *No* to switch off the device or *Yes* to make and receive calls. Do not select *Yes* when wireless phone use may cause interference or danger.

■ Calendar

The calendar keeps track of reminders, calls you need to make, meetings, memo, and birthdays. It can even sound an alarm for any of these events.

The default monthly view provides an overview of the selected month and weeks. You can also jump to a specific date. Any days or dates that appear in bold font contain calendar notes such as a meeting or reminder. A short summary of notes for the day appear at the bottom of the screen.

Open calendar

In the standby mode, select *Menu > Organizer > Calendar*.

Scroll to move the cursor in the calendar view.

Calendar options

In the standby mode, select *Menu > Organizer > Calendar > Options* and one of the following:

Week view—View your calendar by weeks. To return to month view select *Back*, while in the *Week view*.

Make a note—Create a note on the selected date.

Go to date—Jump to a specific date. Enter the date (for example, 15/07/2005), and select *OK*.

Go to today—Jump to the current date.

Settings—Modify the calendar settings.

Go to to-do list—Go directly to your to-do list.

Delete all notes—Delete all calendar notes. This option appears only if a calendar note has been created.

Make a calendar note

You can make a calendar note for a specific date. You can select from five types of notes. Your phone asks for further information depending on which note you select. You can also set an alarm for your note.

1. In the standby mode, select *Menu > Organizer > Calendar*.
2. Scroll to the date for which you want to make a note. Scroll or select *Options > Go to date*.
3. Select *Options > Make a note* and one of the following:
 - Meeting*—Enter the subject, and select *Save*. Enter a location, and select *Save*. Enter a start and end time. Select an alarm option.
 - Call*—Enter the phone number, and select *Save*. Enter a name, and select *Save*. Enter a time. Select an alarm option. You can also select *Options > Search* to search your contacts.
 - Birthday*—Enter the person's name, and select *Save*. Enter the year of birth. Select an alarm option.
 - Memo*—Enter the subject, and select *Save*. Enter a start and end date. Select an alarm option.
 - Reminder*—Enter the reminder, and select *Save*. Select an alarm option.

View calendar notes (day view)

You can view the calendar notes for a day.

1. In the standby mode, select *Menu > Organizer > Calendar*.
2. Scroll to the date you want to view or select *Options > Go to date*. Days with notes appear in bold type.
3. Select *View* to see the list of notes for that day.

To view a specific note, scroll to the note, and select *View* again. If there are no notes for that date, select *Add note* to create a new calendar note.

Options while viewing a day

When viewing the list of notes for a day, you can scroll to a note, select *Options* and one of the following:

Make a note—Create a new note for the selected date.

Delete—Delete the note.

Edit—Edit the note.

Use detail—Use a detail contained in the note.

Move—Move the note to another date on your calendar.

Repeat—Enable the note to recur on a regular basis (daily, weekly, biweekly, monthly, and yearly). *Repeat* is not available for *Birthday* note.

Go to date—Jump to another date on your calendar.

Go to today—Return to the current date.

Send note > *Send as message*, *Via calendar*, or *Via Bluetooth*—Send a calendar note in calendar format (vCal), in a text message or directly to another device.

Copy—Copy the note. You can paste the note to another date.

Settings—Modify the calendar settings.

Go to to-do list—Go directly to your to-do list.

Receive a note in calendar format (vCal)

When you receive a calendar note in calendar-to-calendar format (vCal), your phone displays *Calendar note received*.

Select *Show* to view the calendar note. Select *Save* to save the note to your calendar or *Options* > *Discard* to discard the note.

Modify calendar settings

In the standby mode, select *Menu* > *Organizer* > *Calendar* > *Options* > *Settings* and one of the following:

Set the date—Enter the current date, and select *OK*.

Set the time—Enter the current time, and select *OK*.

Time zone—Select your current time zone.

Date format—Select your preferred date format.

Date separator—Select your preferred date separator.

Time format—Select your preferred time format.

Default view—Select a monthly or weekly view.

Week starts—Select the day the week starts.

Auto-delete notes—Select when to delete past notes.

■ Notes

You can write text notes with the *Notes*. You can also send notes using text message or Bluetooth connectivity.

Open notes

In the standby mode, select *Menu > Organizer > Notes*. The current list of notes is displayed.

If there are no notes, select *Add* to create your first note. If there are existing notes, scroll to a note, and select *View*.

Make a note

Initial note

In the standby mode, select *Menu > Organizer > Notes > Add*. Create your note, and select *Save*.

Additional notes

In the standby mode, select *Menu > Organizer > Notes > Options > Make a note*. Create your note, select any note options, and select *Save*.

Create note options

When you create a note, the following options are available:

Insert time & date—Adds the time and date to your note.

Close—Returns you to the notes list.

Insert smiley—Inserts a smiley into your message.

Insert word or *Edit word*—Enter or edit the text of a new word that might not appear in the predictive text dictionary. The option only appears when predictive text is on.

Insert symbol—Inserts a special character into your message. Option only appears when predictive text is on.

Writing language—Select the language you want to use.

Prediction on or *Prediction off*—Turn predictive text on or off.

Matches—View matches found in the predictive text dictionary for the word you want to use. This is displayed only when predictive text is on.

Send a note

1. In the standby mode, select *Menu > Organizer > Notes*.
2. Scroll to the note you wish to send, and select *Options > Send note > Send as message*, or *Via Bluetooth* to send the note in a text message or directly to another device.

Notes options

In the standby mode, select *Menu > Organizer > Notes > Options* and one of the following:

Make a note—Create a new note.

Delete—Delete the note you selected.

Edit—Edit the note you selected.

Use detail—Use a detail contained in the note.

Send note > Send as message, or Via Bluetooth—Send a note in a text message or directly to another device.

Delete all notes—Delete all notes.

The note options are displayed only when you have created one or more notes.

■ To-do list

Use the *To-do list* feature to keep track of your tasks. You can save a task or errand as a to-do list note, select a priority level for the to-do list note, and mark it as done when you have completed it. You can sort the to-do list notes by priority or by date.

Open to-do list

In the standby mode, select *Menu > Organizer > To-do list*. The current to-do list is displayed.

If there are no to-do tasks, select *Add* to create your first to-do list note. If there are existing to-do list notes, scroll to a to-do list note, and select *View*.

Make a to-do list note

Initial to-do list note

In the standby mode, select *Menu > Organizer > To-do list > Add*. Enter the subject, and select *Save > High, Medium, or Low*.

Additional to-do list notes

In the standby mode, select *Menu > Organizer > To-do list > Options > Add*. Enter the subject, and select *Save > High, Medium, or Low*.

Create to-do list note options

When you create a to-do list note, the following options are available:

Insert smiley—Insert a smiley into your message.

Insert word or Edit word—Enter or edit the text of a new word that might not appear in the predictive text dictionary. The option is displayed only when predictive text is on.

Insert symbol—Insert a special character into your message. The option is displayed only when predictive text is on.

Writing language—Select the language you want to use.

Prediction on or Prediction off—Turn predictive text on or off.

Matches—View matches found in the predictive text dictionary for the word you want to use. The option is displayed only when predictive text is on.

Edit to-do list notes

In the standby mode, select *Menu > Organizer > To-do list > View > Edit*. Edit the subject, select *Save*.

View to-do list notes

In the standby mode, select *Menu > Organizer > To-do list > View > Options*, and one of the following choices:

Deadline—Change the deadline of the to-do list note.

Mark note as done or Mark as not done—Indicate whether the to-do list note is completed or not.

Delete—Delete the to-do list note.

Use detail—Use a detail contained in the note.

Edit priority—Change the priority to *High*, *Medium*, or *Low*.

Send > Send as message, Via calendar, or Via Bluetooth—Send the to-do list note.

Go to calendar—Leave the to-do list, and go to the calendar.

Save to calendar—Save the to-do list note to your calendar.

Send a to-do list note

1. In the standby mode, select *Menu > Organizer > To-do list*.
2. Scroll to the note you wish to send, and select *Options > Send > Send as message, Via calendar, or Via Bluetooth* to send the to-do list note in calendar format (vCal), in a text message or directly to another device.

To-do list options

In the standby mode, select *Menu > Organizer > To-do list > Options* and one of the following:

Add—Create a new to-do list note.

Organizer

Delete—Delete the to-do list note you selected.

Mark note as done or *Mark as not done*—Indicate whether the to-do list note is completed or not.

Use detail—Use a detail contained in the note.

Sort by deadline or *Sort by priority*—Sort the to-do list by either date or priority.

Send > *Send as message*, *Via calendar*, or *Via Bluetooth*—Send the to-do list note in calendar format (vCal), in a text message or directly to another device.

Go to calendar—Leave the to-do list, and go to the calendar.

Save to calendar—Save the to-do list note you selected to your calendar.

Delete done notes—Delete the to-do list note you selected from your calendar.

Delete all notes—Delete all the to-do list notes.

The to-do list options appear only when you have created one or more notes.

■ Calculator

The calculator in your phone adds, subtracts, multiplies, divides, calculates the square and the square root, changes the sign of the number entered, and converts currency values.



Note: This calculator has a limited accuracy and is designed for simple calculations.

Use calculator

1. In the standby mode, select *Menu* > *Organizer* > *Calculator*.
2. Enter the first number in the calculation.
Press # for a decimal point if necessary.
Press the scroll key up or down to change the sign of your number or value.
Press * to cycle through the add (+), subtract (-), multiply (*), and divide (/) characters. Pause briefly to select the displayed character.
3. Enter the second number in your calculation.
4. Select *Equals*.

To perform a square or square root calculation, select *Options* > *Square* or *Square root*.

Currency converter

You can convert foreign currency to domestic, or vice versa, directly from the standby mode or from the *Calculator* menu.



Note: When you change base currency, you must enter the new rates because all previously set exchange rates are set to zero.

1. In the standby mode, select *Menu > Organizer > Calculator > Options > Exchange rate > Foreign units in home units* or *Home units in foreign units*.
Foreign units in home—The number of home units it takes to make one unit of foreign currency.
Home units in foreign—The number of foreign units it takes to make one unit of your home currency.
2. Enter the exchange rate (press # to insert a decimal), and select *OK*.
3. Select *Back* to return to the *Calculator* screen, and enter the currency amount to convert.
4. Select *Options > To home* or *To foreign*.
To home—Converts foreign currency to domestic currency.
To foreign—Converts domestic currency to foreign currency.
5. If you have not already entered an exchange rate, the device prompts you to enter it. Select *OK*. You can edit the exchange rate at any time.

■ Timers

Your device contains two event timers: a normal timer that counts down a set interval, and an interval timer that counts up set intervals. The timers only work when the phone is on. Once you turn off your phone, the timers are no longer active.

Normal timer

This countdown timer enables you to enter a specific duration (up to 99 hours, 59 minutes, and 59 seconds). When the time runs out, your device sounds an alarm.

Set the normal timer

1. In the standby mode, select *Menu > Organizer > Timer > Normal timer*.
2. Enter the time (in hh:mm:ss format), and select *OK*.
3. Enter a note for the timer, and select *Start*.

 and the timer (in hh:mm:ss format) appear in the standby mode when the countdown timer is running.

When the time runs out, your phone sounds an alarm, vibrates, and flashes its lights. If you are in the standby mode, select *Restart* or *Exit*. If you are not in the standby mode, press any key during the alarm to stop the timer.

After 60 seconds the timer alert expires automatically. Select *Exit* or press the end key to clear the timer note.

Change the timer

After you have set a timer, you can change the time.

1. In the standby mode, select *Menu > Organizer > Timer > Change time*.
2. Enter the new time, and select *OK*.
3. Leave the note as it was, or enter a new note, and select *Start*.

Stop the timer before the alarm sounds

After you have set the timer, you can stop the timer.

In the standby mode, select *Menu > Organizer > Timer > Stop timer*.

Interval timer

The interval timer in your device allows you to store multiple interval timers. You can define and store up to 10 timing periods for each interval timer. Once at least one interval timer is set and stored, you can select the interval timer and one of the stored intervals for that timer. When the selected interval expires, your phone sounds an alarm, vibrates, and flashes its lights.

Set an interval timer

1. In the standby mode, select *Menu > Organizer > Timer > Interval timer*.
2. Select *Add new timer*. This option only appears if you have already created an interval timer.
3. Enter a name for the timer and select *Save*.
4. Enter a name for the first timer period, and select *Save*.
5. Enter the desired time interval, and select *OK*.
6. Select an existing stored period and *Edit period*, *Add period*, *Delete period*, or *Start timer*.

Use an interval timer

1. In the standby mode, select *Menu > Organizer > Timer > Interval timer*.
2. Select *Start timer*, *View timer*, *Edit timer*, *Add new timer*, or *Delete timer*. These options only appear if you have already created an interval timer.

■ Stopwatch

Your phone has a stopwatch that can be used to track time. The stopwatch displays time in hours, minutes, seconds, and fractions of a second in hh:mm:ss.ss format.

Using the stopwatch or allowing it to run in the background when using other features increases the demand on battery power and reduces the battery life.

Measure split or lap time

Use the split time or lap time functions for activities where you need to pace yourself.

1. In the standby mode, select *Menu > Organizer > Stopwatch > Split timing or Lap timing > Start*.

Split timing—Use the split time function for such activities as a long distance race when you need to pace yourself. Select *Split* to note the lapsed time. The timer continues to run and the split time appears below the running time.

Each time you select *Split*, the new measured time appears at the beginning of the list. The maximum number of splits is 20.

Lap timing—Use the lap time function when you want to track how long it takes to complete each cycle or lap. Select *Lap* to note the lap time. The clock stops, then immediately restarts from zero. The lap time appears below the running time. Each time you select *Lap*, the new measured time appears at the beginning of the list. The maximum number of laps is 20.

2. Select *Stop* to end timing and display total time.

Save a time

To save a time while the clock is running, select *Stop > Save*, enter a name for the measurement, and select *OK*. If you do not enter a name, the total time is used as the default title for the lap or split time.

Stopwatch options

In the standby mode, select *Menu > Organizer > Stopwatch* and one of the following:

Continue—Continues to measure time. Only appears if clock is running and you are returning to stopwatch screen.

Show last time—View the last measured time.

Split timing—Use the split time function.

Lap timing—Use the lap time function.

View times—Browse saved times.

Delete times > One by one or Delete all—Delete saved times.

Operation note

If you press the end key and return to the standby mode, the clock continues to run in the background, and  appears at the top of the screen.

To return to the *Stopwatch* screen, do the following:

1. In the standby mode, select *Menu > Organizer > Stopwatch > Continue*.
2. To stop the clock, select *Stop*.

11. PC connectivity

■ PC data transfer

You can transfer data, such as music, photos, and videos, from your device to a compatible PC or from a compatible PC to your device using Bluetooth connectivity. For more information, see "Bluetooth connectivity," p. 44.

■ Nokia PC Suite

Nokia PC Suite software is available for this phone. Nokia PC Suite is a collection of powerful tools that you can use to manage your phone features and data. Each component is a separate program that includes online help.

Nokia PC Suite software, installation instructions, and other documentation is provided free of charge and can be downloaded from the software downloads of the Nokia web site: www.nokiausa.com/pcsuite.

Some of the features in your phone require network support. Contact your service provider for availability and configuration instructions.

Remember to make back-up copies of all important data.

12. Enhancements



Check the model number of any charger before use with this device. This device is intended for use when supplied with power from the AC-3 or AC-4 charger.



Warning: Use only batteries, chargers and enhancements approved by Nokia for use with this particular model. The use of any other types may invalidate any approval or warranty, and may be dangerous.

For availability of approved enhancements, please check with your dealer. When you disconnect the power cord of any enhancement, grasp and pull the plug, not the cord.

A few practical rules about accessories and enhancements:

- Keep all accessories and enhancements out of the reach of small children.
- When you disconnect the power cord of any accessory or enhancement, grasp and pull the plug, not the cord.
- Check regularly that enhancements installed in a vehicle are mounted and are operating properly.
- Installation of any complex car enhancements must be made by qualified personnel only.

Power

- Standard 1150 mAh Li-Ion Battery (BL-6C)
- Compact Charger (AC-3)
- Travel Charger (AC-4)
- Mobile Charger (DC-4)
- Charger Adapter (CA-44)

Use the CA-44 charger adapter to connect the phone with Nokia chargers with a larger barrel size, including ACP-7, ACP-8, ACP-9, ACP-12, AC-1 (retractable charger), and LCH-12 (mobile charger).

USB data cable

- Connectivity Cable (CA-53)

Enhancements

Handsfree

- Headrest Handsfree (BHF-3)
- CDMA Headrest Handsfree (BHF-4)
- Easy to Use Car Handsfree (HF-3)
- Advanced Plug-in Car Handsfree (HF-6)
- Wireless Plug-in Car Handsfree (HF-6W)

Headsets

- Mono Headsets (HDB-4, HS-5, HS-6, HS-8, HS-9)
- Stereo Headsets (HDS-3, HS-3, HS-23)
- Wireless Mono Headsets (HDW-3, HS-4W, HS-11W, HS-21W, HS-36W, HS-37W))
- Wireless Image Headsets (HS-13W)
- Wireless Stereo Headsets (HS-12W)

Miscellaneous

- Inductive Loopset (LPS-4)
- TTY Adapter (HDA-10)
- Advanced Car Kit (CK-1W)
- Wireless Car Kit (CK-7W)
- Digital Pen (SU-1B)
- Audio Adapter (AD-15)
- Music Stand (MD-1)

13. Reference information

This section provides information about your phone batteries, enhancements, chargers, safety guidelines, and technical information. Be aware that the information in this section is subject to change as batteries, chargers, and enhancements change.

■ Batteries and chargers

Your device is powered by a rechargeable battery. The full performance of a new battery is achieved only after two or three complete charge and discharge cycles. The battery can be charged and discharged hundreds of times, but it will eventually wear out. When the talk and standby times are noticeably shorter than normal, replace the battery. Use only Nokia approved batteries, and recharge your battery only with Nokia approved chargers designated for this device.

If a replacement battery is being used for the first time or if the battery has not been used for a prolonged period, it may be necessary to connect the charger and then disconnect and reconnect it to start the charging.

Unplug the charger from the electrical plug and the device when not in use. Do not leave fully charged battery connected to a charger, since overcharging may shorten its lifetime. If left unused, a fully charged battery will lose its charge over time.

If the battery is completely discharged, it may take a few minutes before the charging indicator appears on the display or before any calls can be made.

Use the battery only for its intended purpose. Never use any charger or battery that is damaged.

Do not short-circuit the battery. Accidental short-circuiting can occur when a metallic object such as a coin, clip, or pen causes direct connection of the positive (+) and negative (-) terminals of the battery. (These look like metal strips on the battery.) This might happen, for example, when you carry a spare battery in your pocket or purse. Short-circuiting the terminals may damage the battery or the connecting object.

Leaving the battery in hot or cold places, such as in a closed car in summer or winter conditions, will reduce the capacity and lifetime of the battery. Always try to keep the battery between 15°C and 25°C (59°F and 77°F). A device with a hot or cold battery may not work temporarily, even when the battery is fully charged. Battery performance is particularly limited in temperatures well below freezing.

Do not dispose of batteries in a fire as they may explode. Batteries may also explode if damaged. Dispose of batteries according to local regulations. Please recycle when possible. Do not dispose as household waste.

■ Nokia battery authentication guidelines

Always use original Nokia batteries for your safety. To check that you are getting an original Nokia battery, purchase it from an authorized Nokia dealer, look for the Nokia Original Enhancements logo on the packaging and inspect the hologram label using the following steps:

Successful completion of the three steps is not a total assurance of the authenticity of the battery. If you have any reason to believe that your battery is not an authentic original Nokia battery, you should refrain from using it and take it to the nearest authorized Nokia service point or dealer for assistance. Your authorized Nokia service point or dealer will inspect the battery for authenticity. If authenticity cannot be verified, return the battery to the place of purchase.

Authenticate hologram



1. When looking at the hologram on the label, you should see the Nokia connecting hands symbol from one angle and the Nokia Original Enhancements logo when looking from another angle.



2. When you angle the hologram left, right, down, and up, you should see 1, 2, 3, and 4 dots on each side respectively.

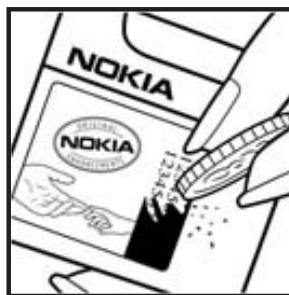

3. Scratch the side of the label to reveal a 20-digit code, for example 12345678919876543210. Turn the battery so that the numbers are facing upwards. The 20-digit code reads starting from the number at the top row followed by the bottom row. Confirm that the 20-digit code is valid by following the instructions at www.nokia.com/batterycheck.

What if your battery is not authentic?

If you cannot confirm that your Nokia battery with the hologram on the label is an authentic Nokia battery, please do not use the battery. Take it to the nearest authorized Nokia service point or dealer for assistance. The use of a battery that is not approved by the manufacturer may be dangerous and may result in poor performance and damage to your device and its enhancements. It may also invalidate any approval or warranty applying to the device.

To find out more about original Nokia batteries, visit www.nokia.com/battery.

Care and maintenance

Your device is a product of superior design and craftsmanship and should be treated with care. The suggestions below will help you protect your warranty coverage.

- Keep the device dry. Precipitation, humidity and all types of liquids or moisture can contain minerals that will corrode electronic circuits. If your device does get wet, remove the battery and allow the device to dry completely before replacing it.
- Do not use or store the device in dusty, dirty areas. Its moving parts and electronic components can be damaged.
- Do not store the device in hot areas. High temperatures can shorten the life of electronic devices, damage batteries, and warp or melt certain plastics.
- Do not store the device in cold areas. When the device returns to its normal temperature, moisture can form inside the device and damage electronic circuit boards.
- Do not attempt to open the device other than as instructed in this guide.
- Do not drop, knock, or shake the device. Rough handling can break internal circuit boards and fine mechanics.
- Do not use harsh chemicals, cleaning solvents, or strong detergents to clean the device.
- Do not paint the device. Paint can clog the moving parts and prevent proper operation.
- Use only the supplied or an approved replacement antenna. Unauthorized antennas, modifications, or attachments could damage the device and may violate regulations governing radio devices.
- Use chargers indoors.
- Always create a backup of data you want to keep, such as contacts and calendar notes, before sending your device to a service facility.

All of the above suggestions apply equally to your device, battery, charger, or any enhancement. If any device is not working properly, take it to the nearest authorized service facility for service.

Additional safety information

Your device and its enhancements may contain small parts. Keep them out of the reach of small children.

■ Operating environment

Remember to follow any special regulations in force in any area and always switch off your device when its use is prohibited or when it may cause interference or danger. Use the device only in its normal operating positions.

This device meets RF exposure guidelines when used either in the normal use position against the ear or when positioned at least 2.2 centimeters (7/8 inch) away from the body. When a carry case, belt clip or holder is used for body-worn operation, it should not contain metal and should position the device the above-stated distance from your body.

To transmit data files or messages, this device requires a good quality connection to the network. In some cases, transmission of data files or messages may be delayed until such a connection is available. Ensure the above separation distance instructions are followed until the transmission is completed.

Parts of the device are magnetic. Metallic materials may be attracted to the device. Do not place credit cards or other magnetic storage media near the device, because information stored on them may be erased.

Your device and its enhancements may contain small parts. Keep them out of the reach of small children.

■ Medical devices

Operation of any radio transmitting equipment, including wireless phones, may interfere with the functionality of inadequately protected medical devices. Consult a physician or the manufacturer of the medical device to determine if they are adequately shielded from external RF energy or if you have any questions. Switch off your device in health care facilities when any regulations posted in these areas instruct you to do so. Hospitals or health care facilities may be using equipment that could be sensitive to external RF energy.

Additional safety information

Pacemakers

Pacemaker manufacturers recommend that a minimum separation of 15.3 centimeters (6 inches) be maintained between a wireless phone and a pacemaker to avoid potential interference with the pacemaker. These recommendations are consistent with the independent research by and recommendations of Wireless Technology Research. Persons with pacemakers should:

- Always keep the device more than 15.3 centimeters (6 inches) from the pacemaker;
- Not carry the device in a breast pocket; and
- Hold the device to the ear opposite the pacemaker to minimize the potential for interference.

If you suspect interference, switch off your device and move the device away.

Hearing aids

Some digital wireless devices may interfere with some hearing aids. If interference occurs, consult your service provider.

■ Vehicles

RF signals may affect improperly installed or inadequately shielded electronic systems in motor vehicles such as electronic fuel injection systems, electronic antiskid (antilock) braking systems, electronic speed control systems, air bag systems. For more information, check with the manufacturer or its representative of your vehicle or any equipment that has been added.

Only qualified personnel should service the device, or install the device in a vehicle. Faulty installation or service may be dangerous and may invalidate any warranty that may apply to the device. Check regularly that all wireless device equipment in your vehicle is mounted and operating properly. Do not store or carry flammable liquids, gases, or explosive materials in the same compartment as the device, its parts, or enhancements. For vehicles equipped with an air bag, remember that air bags inflate with great force. Do not place objects, including installed or portable wireless equipment in the area over the air bag or in the air bag deployment area. If in-vehicle wireless equipment is improperly installed and the air bag inflates, serious injury could result.

Using your device while flying in aircraft is prohibited. Switch off your device before boarding an aircraft. The use of wireless teledevices in an aircraft may be dangerous to the operation of the aircraft, disrupt the wireless telephone network, and may be illegal.

■ Potentially explosive environments

Switch off your device when in any area with a potentially explosive atmosphere and obey all signs and instructions. Potentially explosive atmospheres include areas where you would normally be advised to turn off your vehicle engine. Sparks in such areas could cause an explosion or fire resulting in bodily injury or even death. Switch off the device at refuelling points such as near gas pumps at service stations. Observe restrictions on the use of radio equipment in fuel depots, storage, and distribution areas, chemical plants or where blasting operations are in progress. Areas with a potentially explosive atmosphere are often but not always clearly marked. They include below deck on boats, chemical transfer or storage facilities, vehicles using liquefied petroleum gas (such as propane or butane), and areas where the air contains chemicals or particles such as grain, dust, or metal powders.

■ Emergency calls



Important: Wireless phones, including this phone, operate using radio signals, wireless networks, landline networks, and user-programmed functions. Because of this, connections in all conditions cannot be guaranteed. You should never rely solely on any wireless phone for essential communications like medical emergencies.

To make an emergency call:

1. If the phone is not on, switch it on. Check for adequate signal strength.
2. Press the end key as many times as needed to clear the display and ready the phone for calls.
3. Enter the official emergency number for your present location. Emergency numbers vary by location.
4. Press the call key.

If certain features are in use, you may first need to turn those features off before you can make an emergency call. Consult this guide or your service provider.

When making an emergency call, give all the necessary information as accurately as possible. Your wireless phone may be the only means of communication at the scene of an accident. Do not end the call until given permission to do so.

■ Certification information (SAR)

This mobile device meets guidelines for exposure to radio waves.

Your mobile device is a radio transmitter and receiver. It is designed not to exceed the limits recommended by international guidelines. These guidelines were developed by the independent scientific organization ICNIRP and include safety margins designed to assure the protection of all persons, regardless of age and health.

The exposure guidelines for mobile devices employ a unit of measurement known as the Specific Absorption Rate or SAR. The SAR limit set by ICNIRP is 2.0 watts/kilogram (W/kg) averaged over 10 grams of tissue. Tests for SAR are conducted using standard operating positions with the device transmitting at its highest certified power level in all tested frequency bands. The actual SAR level of an operating device can be well below the maximum value because the device is designed to use only the power required to reach the network. That amount changes depending on a number of factors such as how close you are to a network base station. The highest SAR value when tested according to international testing procedures for use at the ear is 0.91 W/kg.

Use of device accessories and enhancements may result in different SAR values. SAR values may vary depending on national reporting and testing requirements and the network band. Additional SAR information may be provided under product information at www.nokia.com.

Your mobile device is also designed to meet the requirements for exposure to radio waves established by the Federal Communications Commission (USA) and Industry Canada. These requirements set a SAR limit of 1.6 W/kg averaged over one gram of tissue. The highest SAR value reported under this standard during product certification for use at the ear is 1.36 W/kg and when properly worn on the body is 0.70 W/kg.

Information about this device can be found on the FCC's website at <http://www.fcc.gov/oet/fccid> by searching the equipment authorization system using FCC ID: QMNRM-124.

■ Hearing aid compatibility (HAC)

Your mobile device model complies with FCC rules governing hearing aid compatibility. These rules require an M3 microphone or higher value. The M-value, shown on the device box, refers to lower radio frequency (RF) emissions. A higher M-value generally indicates that a device model has a lower RF emissions level, which may improve the likelihood that the device will operate with certain hearing aids. Some hearing aids are more immune than others are to interference. Please consult your hearing health professional to determine the M rating of your hearing aid and whether your hearing aid will work with this device. More information on accessibility can be found at www.nokiaaccessibility.com.

For best results fully extend the antenna for hearing aid compatibility.

■ Technical information

Feature	Specification
Dimensions	Width, 43.5 mm; length, 84.8 mm; depth, 25 mm
Weight	124 g with BL-6C Li-Ion Battery
Wireless networks	CDMA 800 and 1900 MHz, AMPS, and Bluetooth wireless technology
Volume	84 cc
Frequency range (Tx)	AMPS: 824.04–848.97 MHz PCS: 1851.25–1908.75 MHz Cellular: 824.70–848.37 MHz
Frequency range (Rx)	AMPS: 869.04–893.97 MHz PCS: 1931.25–1988.75 MHz Cellular: 869.70–893.37 MHz
GPS frequency	1575.42 MHz
Bluetooth wireless technology	2402.0–2480.0 MHz

Additional safety information

■ Battery information

This section provides information about battery charging times with the Compact Charger (AC-3), the Travel Charger (AC-4), talk times, and standby times. Be aware that the information in this section is subject to change. For more information, contact your service provider.

Charging times

The following charging times are approximate with the BL-6C 1150 mAh Li-Ion battery:

Travel Charger (AC-4): up to 1 hour 45 minutes

Compact Charger (AC-3): up to 3 hours 45 minutes

Talk and standby times

Operation times are estimates only and depend on signal strength, phone use, network conditions, features used, battery age and condition (including charging habits), temperatures to which the battery is exposed, and many other factors.

Talk time: 3 to 4 hours (digital)

Standby time: 6 to 10 days

Index

NUMERICS

1-touch dialing 38, 50

A

active profile 42

alarm clock

repeating 63

setting 63

tone 63

allowed number if lock active 58

analog service 55

answer calls 17

fold open 50

antenna 13

anykey answer 50

automatic

keyguard 53

redial 50

update of service 51

voice mail 30

B

back cover

remove 14

replace 15

backlight time-out 44

banner 44

battery

authentication guidelines 78

charge 15

charging times 86

removal 14

remove, replace 14

talk and standby times 86

Bluetooth connectivity 44

receive data 47

set up 46

settings 46

business cards 34

C

calendar

make notes 65

open 64

options 64

receive, send notes 66

settings 66

view 65

call

forward 60

settings 50

summary 52

time 23

waiting 61

call volume 17

caller

groups 36

ID, send my 61

calling cards 51

calls

answer 17

conference 17

make 16

mute phone during 18

options during 18

restrictions 59

show times on display 52

silence 17

certification information (SAR) 84

change lock code 59

charger 57, 77

connect 15

times 86

clock settings. See time and date.

conference calls 17

confirmation tones 48

contacts

add 33

Index

- delete 39
- edit 35
- search 32
- settings 36
- view 32

countdown timer 71
currency converter 70
custom profile 42

D

data transfer 74
date settings. See time and date.
dialed numbers 22
dialing codes 33
digital service 55
display settings 43
distribution lists 29
DTMF tones. See touch tones.

E

emergency calls 83
end calls 17
enhancements 56

- approved 75

F

FCC information 84
feature codes 61
folders. See gallery.

G

gallery

- opening folders 40
- options 40

global positioning system 50
go to functions

- organize 12
- select 12

go to menu 12

H

handsfree settings 56
headset

- connect 16
- settings 56

hearing aid

- settings 57

help

- get 7
- in-phone 11
- text activation 11, 54

I

indicators and icons 9
international prefix 52
Interval timer 72

K

keyguard

- automatic 53
- lock and unlock 18

keypad tones 48

L

language 53
lap time 73
location information sharing 50
lock code

- change 59
- preset 58

logs

- call 22
- clearing 23
- dialed numbers 22
- missed calls 22
- received calls 22

loopset settings 57
loudspeaker 18

M

- maintenance services 7
- make calls 16
- messages
 - minibrowser 31
 - voice 30
- minibrowser
 - call duration 23
 - messages 31
- missed calls 22
- mute phone 18
- my phone number, display 38

N

- navigation key 53
- network
 - services 6, 60
 - settings 54
- Network services settings 60
- no caller IDs 52
- Nokia Care Contact Center 7
- Nokia PC Suite 74
- notes 67

O

- organizer 63

P

- PC connectivity 74
- phone
 - care and maintenance 80
 - language 53
 - lock 58
 - set up your 13
- Phone details 54
- phone settings 53
- predictive text 20
- profiles 42

Q

- quick keys 9

R

- received calls 22
- recording sound 41
- register your phone 7
- repeating alarm 63
- restore factory settings 62
- ring volume 48
- ringing tone for no caller ID 52
- roaming options 55

S

- safety guidelines 4
- safety information
 - battery 86
 - explosive environments 83
 - hearing aids 82
 - pacemakers 82
 - vehicles 82
- screen saver 43
- scroll method 10
- security settings 58
- send my caller ID 61
- set
 - alarm 63
 - date 49
 - time 49
- settings 42
- show call time 52
- sleep mode 44
- snooze time-out 64
- software updates 54
- speed dials. See 1-touch dialing.
- split time 73
- standby mode 9
- standby mode settings 43
- standby time 86
- start-up tone 54
- stopwatch 72

Index

T

- talk time 86
- text entry
 - changing language 19
 - predictive 20
 - standard 19
- text messages
 - create 25
 - delete 28
 - folders 24
 - read 25
 - reply 25
 - send 25
 - settings 28
 - templates 25
- time and date 48
- timed profiles 42
- timer
 - countdown 71
 - interval 72
 - stopwatch 72
- to-do list 68
- tones
 - start-up 54
 - touch 53
 - warning 48

- touch tones 53
- TTY/TDD settings 57
- turn phone on or off 15

U

- update service, automatic 51

V

- vibrating alert 48
- voice
 - commands 55
 - privacy 60
 - recorder 41
- voice messages 30
- voice tags 36
- volume 17
- volume, adjust 17

W

- wallpaper 43
- warning tones 48